



BARRIER

PROFESSIONAL BARRIER

PROFESSIONAL BARRIER ANTI TRIP

PRODUCT CODE PRO
WL 2005MM
W 560MM
H 1000MM

PROANTI
 2005MM
 560MM
 1000MM

WEIGHT (KG) 11.2

11.2

PER PALLET 50

50

PER FULL LOAD 600

600

MATERIAL UVHDPE

UVHDPE

COLOUR FOOT ORANGE / CUSTOM

ORANGE / CUSTOM

COLOUR BLACK

YELLOW

CONFIRMED WIND SPEED 20.1 mph

20.1 mph

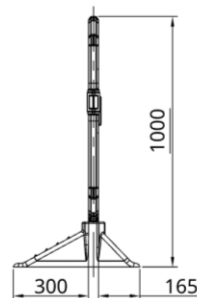
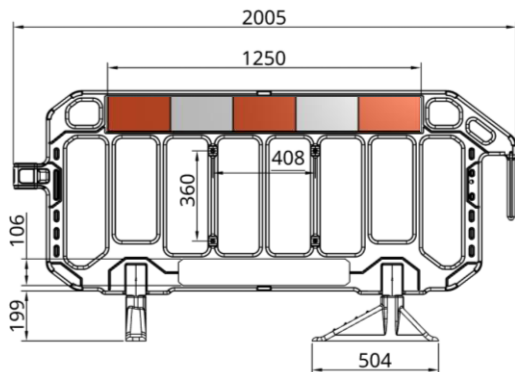



DATA SHEET PROFESSIONAL BARRIER 2 / 3

Chapter 8 & BS compliant Barrier and Reflector for pedestrian delineation

CUSTOM OPTIONS:

Permit Board: 600 x 400mm:
Holes: D=10mm
Spacing: H=409 V=360mm
Dxf file available on request

Removable Standard foot



Removable Hi Vis Anti trip foot



Embossing / Branding area:
W =660 x h =86mm

Custom colours:

- Orange
- Red
- White
- Blue
- Yellow
- Green

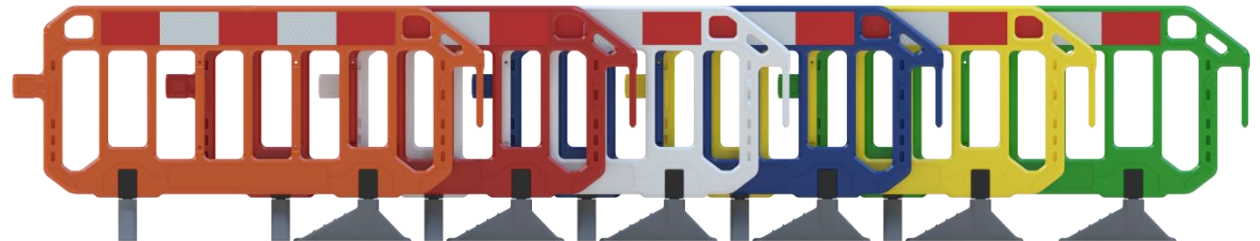
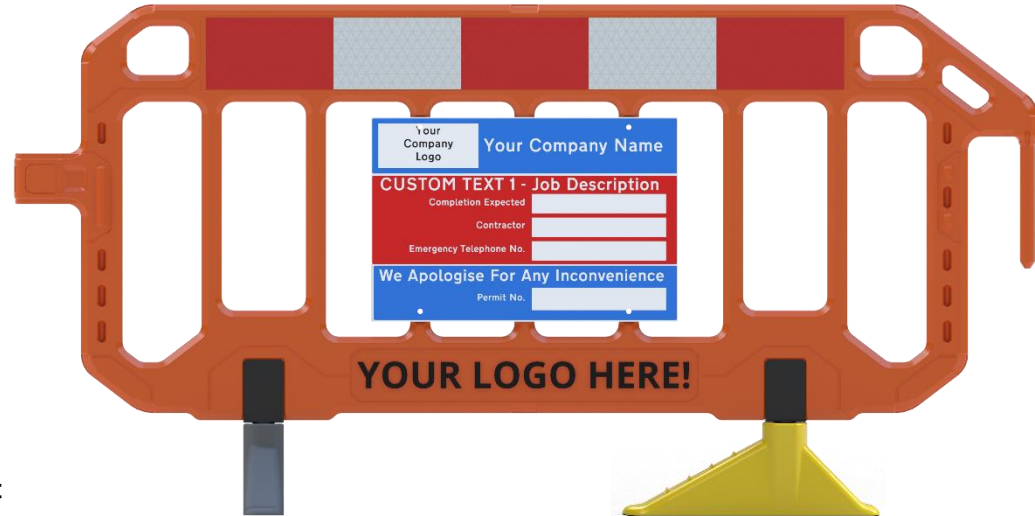



BALLAST REQUIREMENTS (BS 8442: 2006)

	CAT C WIND – 19.5mph	CAT B WIND – 39mph	CAT A WIND – 58mph
BARRIER FLAT	0 KG	40 KG	90 KG
BARRIER BOXED	0 KG	0 KG	60 KG

