

TYPICAL POST AND PANEL FIXING DETAIL

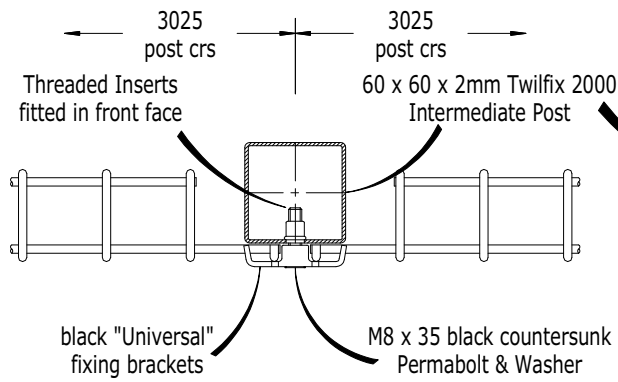

PLAN VIEW ON INTERMEDIATE POST

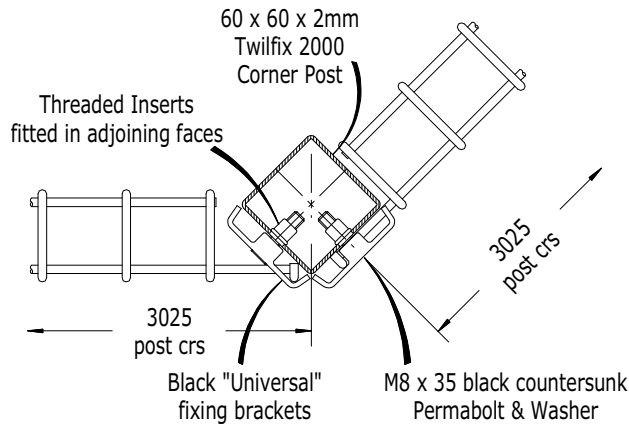

PLAN VIEW ON OBTUSE CORNER POST

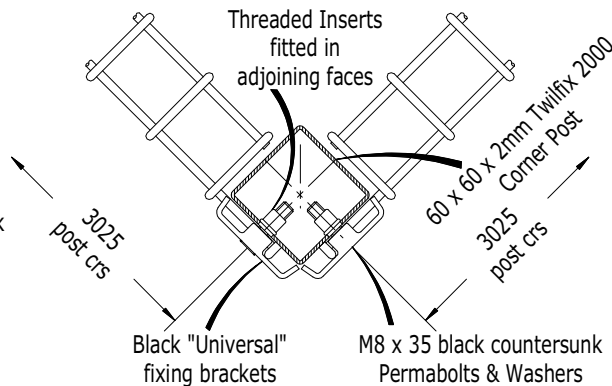

PLAN VIEW ON 90° CORNER POST

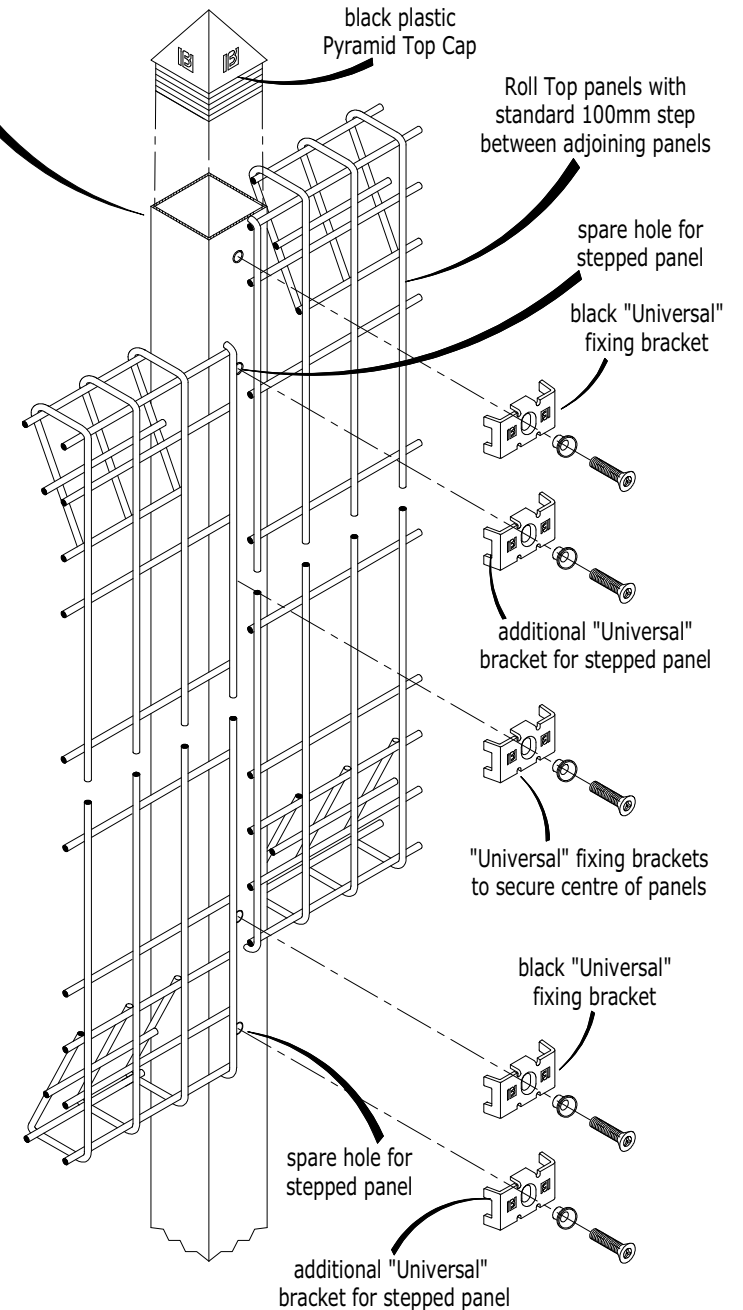

STEPPING DETAIL FOR SLOPING GROUND



www.ridgewayfencing.com

info@ridgewayfencing.com

Ridgefence Roll Top

Drawn

Date

Drawing No :

MJH

09.06.03

REV

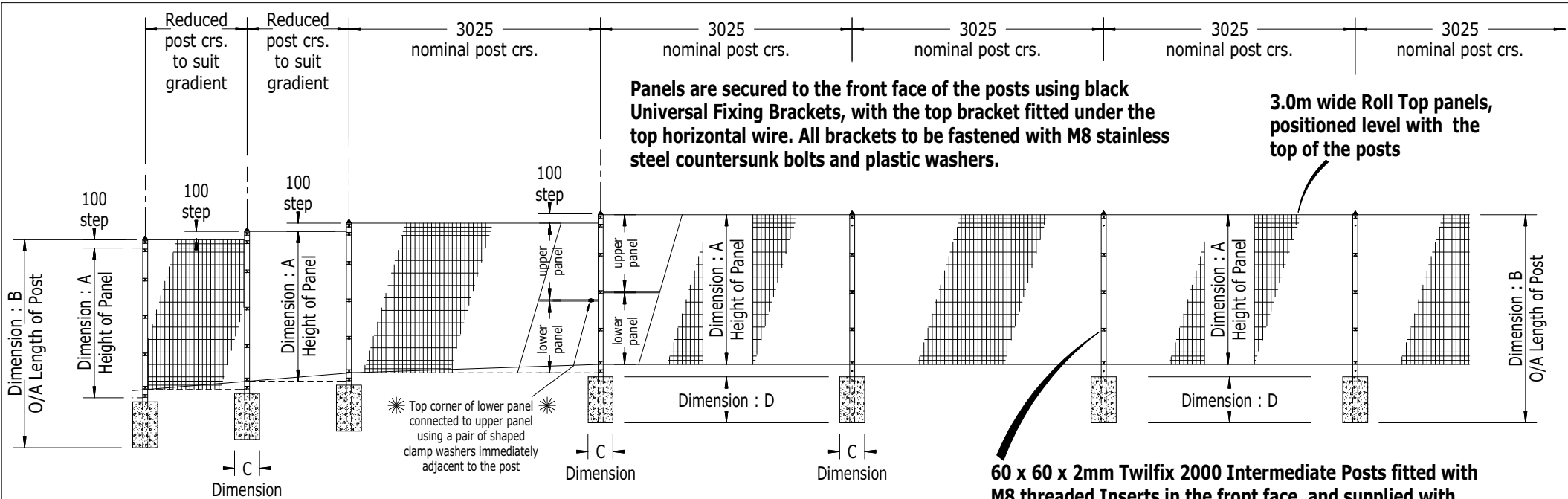

Corner posts

Corner posts are available for Standard 90° external and internal corners, and are also used for obtuse external and internal corners. End posts are not required.

Gradients

All standard Intermediate & Corner posts are fitted with 2no. additional threaded inserts at the top & bottom to facilitate 100mm steps between adjoining panels. Different gradients are achieved by reducing the post centres and width of panel to suit, ie :

- 3000 wide standard panel with 100mm step : 1 in 30 (3.3%) (1.9°)
- 2500 wide standard panel with 100mm step : 1 in 25 (4%) (2.3°)
- 2000 wide site-cut panel with 100mm step : 1 in 20 (5%) (2.9°)
- 1500 wide site-cut panel with 100mm step : 1 in 15 (6.6%) (3.8°)
- 1000 wide site-cut panel with 100mm step : 1 in 10 (10%) (5.7°)

Steeper slopes will require made-to-order extra long posts, manufactured with additional threaded inserts to suit the stepping required between adjoining panels to suit each gradient.

Notes

The preferred method of installation is : Post - Panel - Post - Panel, etc. Bolts may be installed using a Power-Driver and Power-Bit if preferred. When using hand tools, care must be taken to avoid over tightening of bolts.

Concrete Foundations must not be leaner by mass than 1 part cement to 10 parts 20mm nominal size graded aggregates, and must be thoroughly compacted prior to the initial set.

Dim : A Panel Height	Dim : B Length Of Post	Dim : C Size Of Found's	Dim : D Depth Of Found's	Fixings Level Ground	Fixings Sloping Ground
900mm	1500mm	300mm	300mm	3no.	5no.
1200mm	1800mm	300mm	400mm	4no.	6no.
1500mm	2100mm	300mm	500mm	4no.	6no.
1800mm	2500mm	300mm	500mm	5no.	7no.
* 2400mm	3100mm	450mm	500mm	7no.	9no.

* **NOTE : 2.4m high fences** are achieved using 2no. 1.2m high panels, with an upper panel placed directly over a lower panel. Upper and Lower panels are then connected twice per bay using pairs of shaped clamp washers and M8 x 40 stainless steel button-head bolts.

* **Where 2.4m high fences are stepped**, the Top Corner of the lower panel is connected to the upper panel using a pair of shaped clamp washers immediately adjacent to the post.

The Roll Top fencing system generally satisfies the requirements for **Category : 1 (General Purpose) & Category : 2 (Security)** fences as prescribed by B.S. 1722 Part : 14 - Open Mesh Steel Panel Fences



www.ridgeWAYfencing.com

info@ridgeWAYfencing.com

Ridgefence Roll Top

Drawn

MJH

Date

09.06.03

Drawing No :

REV