

1
ALL DIMENSIONS IN MILLIMETRES
REMOVE ALL SHARP EDGES

2
DO NOT JOIN MATERIAL TOGETHER
TO MAKE INDIVIDUAL ITEMS

8
THIRD ANGLE PROJECTION
DO NOT SCALE DRAWING

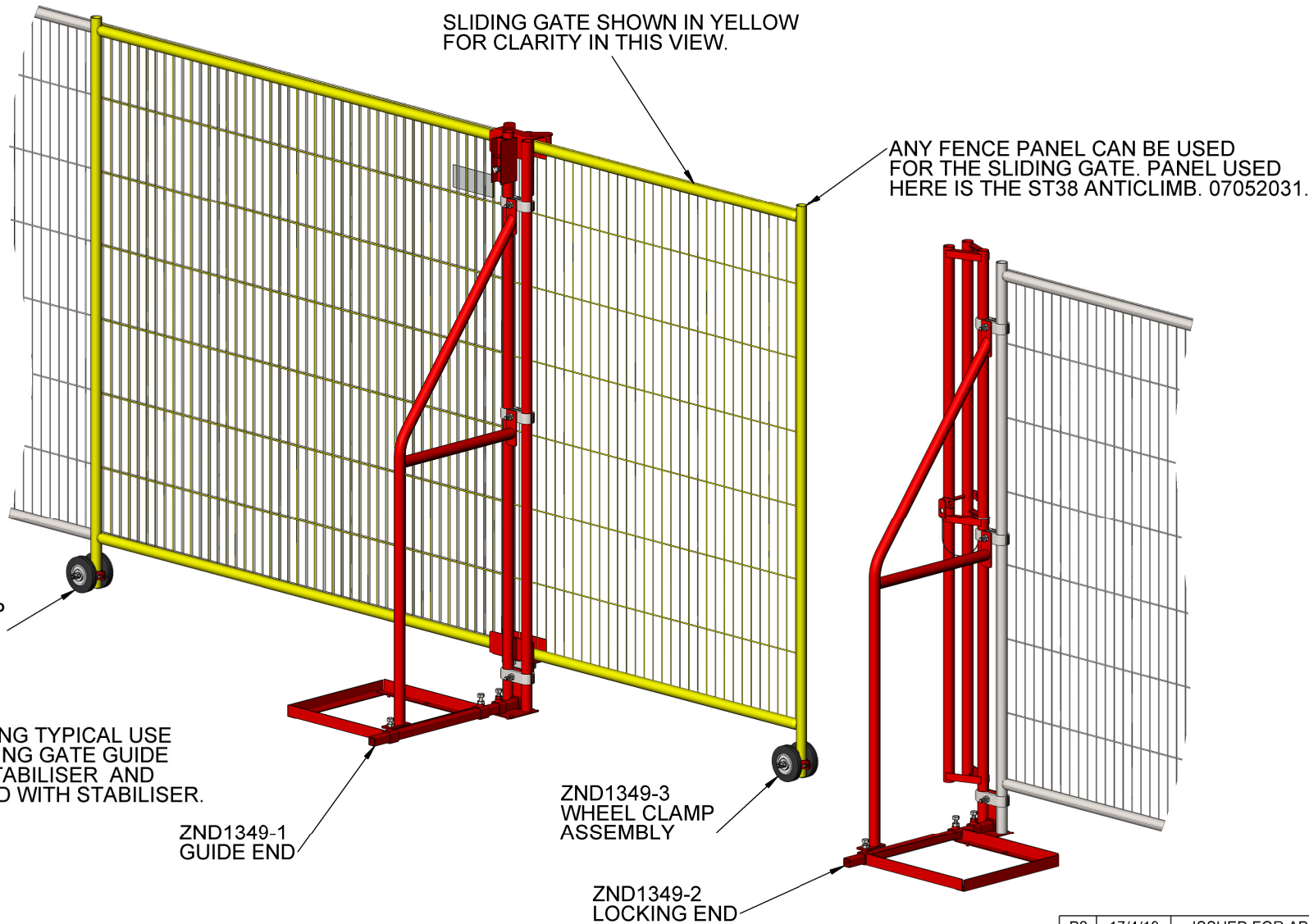

P2	17/4/19	ISSUED FOR APPROVAL	GC	.	.
P1	26/3/19	ISSUED FOR APPROVAL	GC	.	.
REV	DATE	DESCRIPTION	DRN	CHKD	APPR

TOLERANCES - UNLESS STATED OTHERWISE

TITLE:

SLIDING GATE

FABRICATION	UP TO 300mm	+/- 1mm
	UP TO 1000mm	+/- 2mm
	1001mm & ABOVE	+/- 3mm
	ANGULAR	+/- 1°
MACHINING	+/- 0.2mm	
GAUGE	+/- 10%	
WEIGHT	+/- 10% (DUE TO MATERIAL PROPERTIES & TOLERANCES)	

NAME	SIGNATURE	DATE
DRAWN G. CRICK		26/3/19
CHK'D		
FINISH: PAINT POLYESTER POWDERCOAT. COLOUR RAL3020: GUARDS RED		

MATERIAL:
**CARBON STEEL
PRE-GALVANISED**



Belfast: +44 (0) 28 90454599
Ashbourne: +353 (01) 802 7173
Email: info@ridgeway-online.com
Web: www.ridgeway-online.com

Revision
P2

THE COMPANY RETAIN THE RIGHT TO PERIODICALLY ALTER INFORMATION WITHIN THIS DRAWING SHEET AND WILL ATTEMPT TO NOTIFY ALL PARTIES CONCERNED OF ANY CHANGES AND THE INFORMATION ON THIS SHEET SHOULD NOT BE REPRODUCED WITHOUT THEIR WRITTEN CONSENT.

1
ALL DIMENSIONS IN MILLIMETRES
REMOVE ALL SHARP EDGES

2
DO NOT JOIN MATERIAL TOGETHER
TO MAKE INDIVIDUAL ITEMS

8
THIRD ANGLE PROJECTION
DO NOT SCALE DRAWING

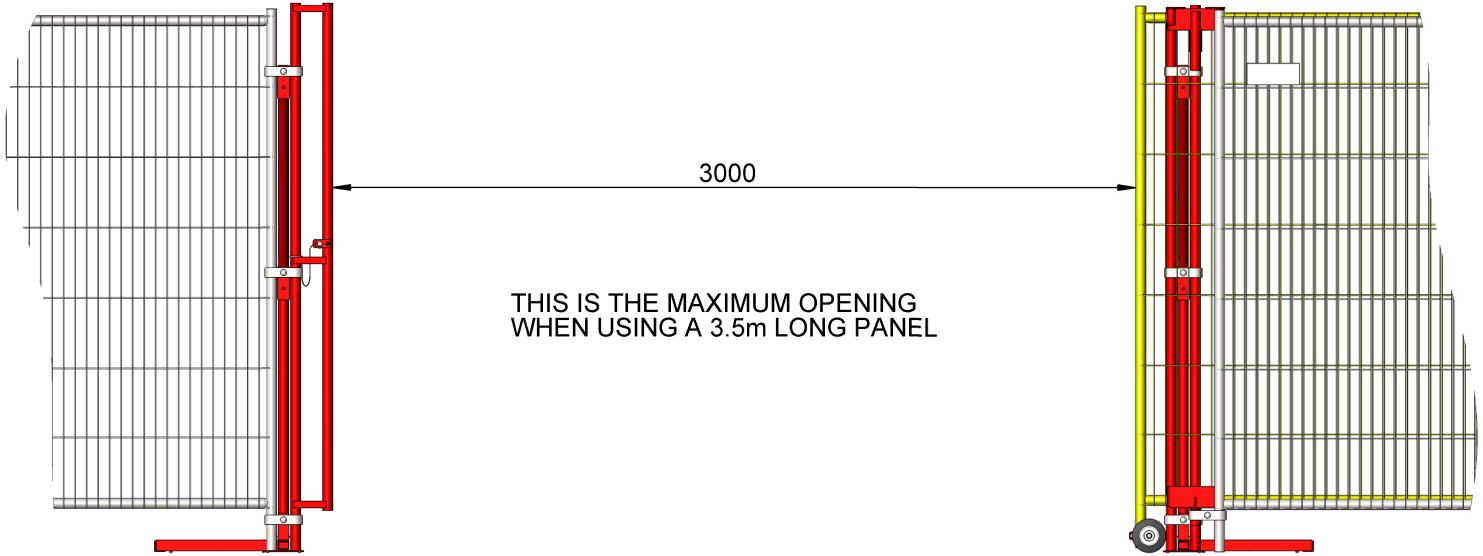

THIS IS THE MAXIMUM OPENING
WHEN USING A 3.5m LONG PANEL

VIEW LOOKING AT THE FRONT

P2	17/4/19	ISSUED FOR APPROVAL	GC	.	.
P1	26/3/19	ISSUED FOR APPROVAL	GC	.	.
REV	DATE	DESCRIPTION	DRN	CHKD	APPR

TOLERANCES - UNLESS STATED OTHERWISE			TITLE: SLIDING GATE MAXIMUM OPENING			
FABRICATION	UP TO 300mm	+/- 1mm	DRAWN	NAME	SIGNATURE	DATE
	UP TO 1000mm	+/- 2mm		G. CRICK		26/3/19
	1001mm & ABOVE	+/- 3mm		CHK'D		
	ANGULAR	+/- 1°	MATERIAL:			
MACHINING	+/- 0.2mm		FINISH: PAINT POLYESTER			
GAUGE	+/- 10%		POWDERCOAT. COLOUR			
WEIGHT	+/- 10% (DUE TO MATERIAL PROPERTIES & TOLERANCES)		RAL3020: GUARDS RED			
			CARBON STEEL PRE-GALVANISED			



Belfast: +44 (0) 28 90454599
 Ashbourne: +353 (01) 802 7173
 Email: info@ridgeway-online.com
 Web: www.ridgeway-online.com

Revision
P2

THE COMPANY RETAIN THE RIGHT TO PERIODICALLY ALTER INFORMATION WITHIN THIS DRAWING SHEET AND WILL ATTEMPT TO NOTIFY ALL PARTIES CONCERNED OF ANY CHANGES AND THE INFORMATION ON THIS SHEET SHOULD NOT BE REPRODUCED WITHOUT THEIR WRITTEN CONSENT.

1 ALL DIMENSIONS IN MILLIMETRES
REMOVE ALL SHARP EDGES

2 DO NOT JOIN MATERIAL TOGETHER
TO MAKE INDIVIDUAL ITEMS

8 THIRD ANGLE PROJECTION
DO NOT SCALE DRAWING

NOTE:
ALL ITEMS ARE TO BE PAINTED
INDIVIDUALLY. ALL SCREW THREADS
ARE TO BE COVERED BEFORE PAINTING.
COUPLERS ARE NOT TO BE PAINTED.

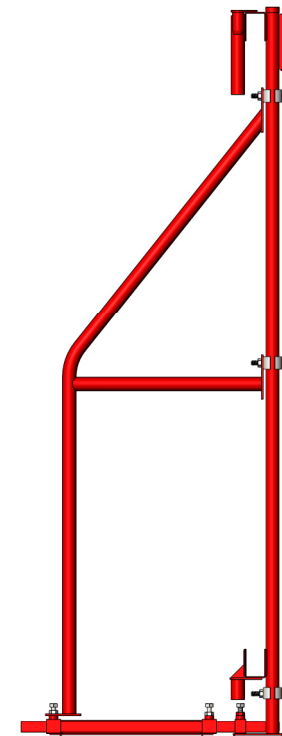
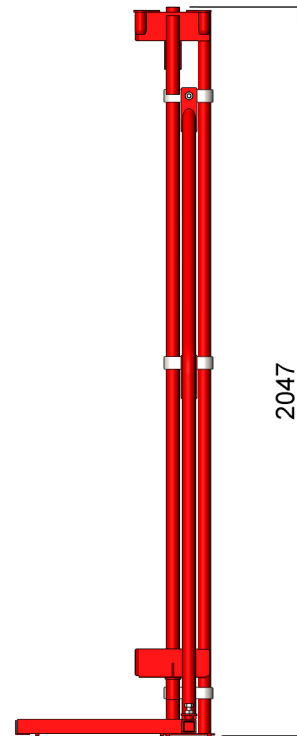
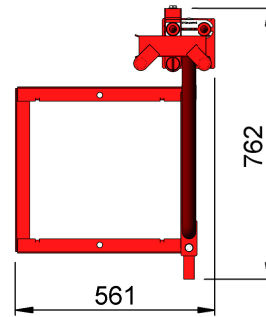
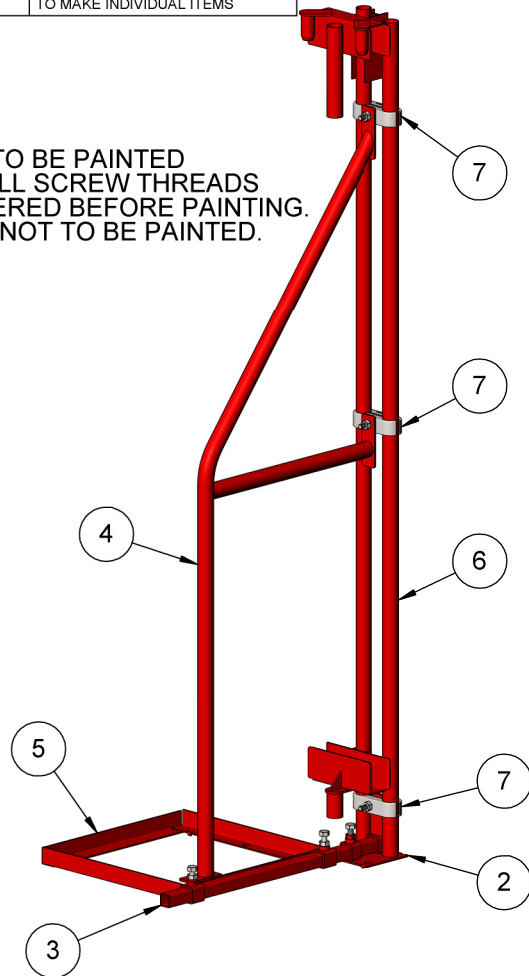

ITEM No.	PART No.	DESCRIPTION	QTY
1	ZND1349-1	GUIDE END FAB	1
2	16552096	WINDBREAKER ZERO-TRIP FOOT	1
3	16552098	WINDBREAKER BOTTOM TUBE - REDUCED	1
4	16552099	WINDBREAKER STABILISER - REDUCED	1
5	16552100	WINDBREAKER BLOCK TRAY	1
6	29051515	∅ 38.1 x 1 x 2025 Lg TUBE	1
7	08551330	HD FENCE COUPLER - GRIPPER	3

P2	17/4/19	ISSUED FOR APPROVAL	GC	.	.
P1	26/3/19	ISSUED FOR APPROVAL	GC	.	.
REV	DATE	DESCRIPTION	DRN	CHKD	APPR

TOLERANCES - UNLESS STATED OTHERWISE

TITLE:

SLIDING GATE GUIDE END + STABILISER



FABRICATION	UP TO 300mm	+/- 1mm	DRAWN	G. CRICK	DATE	26/3/19
	UP TO 1000mm	+/- 2mm				
	1001mm & ABOVE	+/- 3mm				
	ANGULAR	+/- 1°	CHK'D			
MACHINING	+/- 0.2mm		FINISH: PAINT POLYESTER			
GAUGE	+/- 10%		POWDERCOAT. COLOUR			
WEIGHT	+/- 10% (DUE TO MATERIAL PROPERTIES & TOLERANCES)		RAL3020: GUARDS RED			

MATERIAL:
**CARBON STEEL
PRE-GALVANISED**

**CARBON STEEL
PRE-GALVANISED**

Belfast: +44 (0) 28 90454599
Ashbourne: +353 (01) 802 7173
Email: info@ridgeway-online.com
Web: www.ridgeway-online.com

Revision

P2

THE COMPANY RETAIN THE RIGHT TO PERIODICALLY ALTER INFORMATION WITHIN THIS DRAWING SHEET AND WILL ATTEMPT TO NOTIFY ALL PARTIES CONCERNED OF ANY CHANGES AND THE INFORMATION ON THIS SHEET SHOULD NOT BE REPRODUCED WITHOUT THEIR WRITTEN CONSENT.

WEIGHT:

SCALE: 1:12.5

SHEET 3 OF 32

A3

1
ALL DIMENSIONS IN MILLIMETRES
REMOVE ALL SHARP EDGES

2
DO NOT JOIN MATERIAL TOGETHER
TO MAKE INDIVIDUAL ITEMS

8
THIRD ANGLE PROJECTION
DO NOT SCALE DRAWING

NOTE:
ALL ITEMS ARE TO BE PAINTED
INDIVIDUALLY. ALL SCREW THREADS
ARE TO BE COVERED BEFORE PAINTING.
COUPLERS ARE NOT TO BE PAINTED.

ITEM No.	PART No.	DESCRIPTION	QTY
1	ZND1349-1	GUIDE END FAB	1
2	16552096	WINDBREAKER ZERO-TRIP FOOT	1
3	16552098	WINDBREAKER BOTTOM TUBE - REDUCED	1
4	16552099	WINDBREAKER STABILISER - REDUCED	1
5	16552100	WINDBREAKER BLOCK TRAY	1
6	29051515	Ø 38.1 x 1 x 2025 Lg TUBE	1

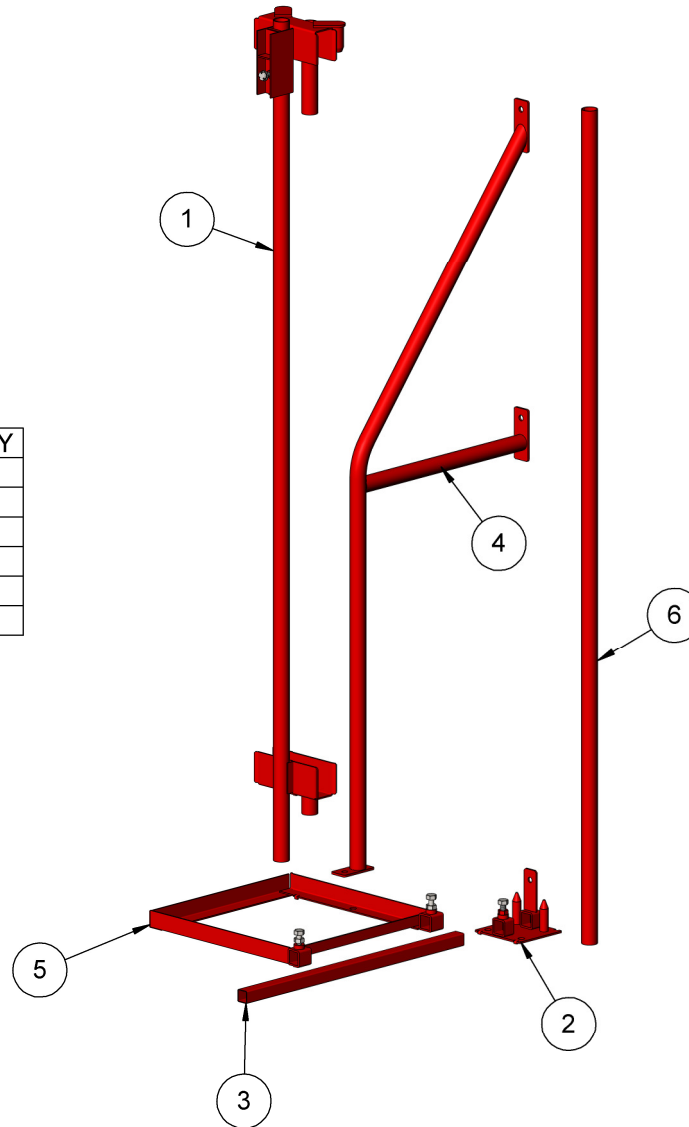

P2	17/4/19	ISSUED FOR APPROVAL	GC	.	.
P1	26/3/19	ISSUED FOR APPROVAL	GC	.	.
REV	DATE	DESCRIPTION	DRN	CHKD	APPR

TOLERANCES - UNLESS STATED OTHERWISE		
FABRICATION	UP TO 300mm	+/- 1mm
	UP TO 1000mm	+/- 2mm
	1001mm & ABOVE	+/- 3mm
	ANGULAR	+/- 1°
MACHINING	+/- 0.2mm	
GAUGE	+/- 10%	
WEIGHT	+/- 10% (DUE TO MATERIAL PROPERTIES & TOLERANCES)	

TITLE: SLIDING GATE GUIDE END PARTS TO BE PAINTED			
NAME	SIGNATURE	DATE	MATERIAL:
G. CRICK		26/3/19	CARBON STEEL PRE-GALVANISED
CHK'D			
FINISH: PAINT POLYESTER POWDERCOAT. COLOUR RAL3020: GUARDS RED			



Belfast: +44 (0) 28 90454599
Ashbourne: +353 (01) 802 7173
Email: info@ridgeway-online.com
Web: www.ridgeway-online.com

Revision

P2

THE COMPANY RETAIN THE RIGHT TO PERIODICALLY ALTER INFORMATION WITHIN THIS DRAWING SHEET AND WILL ATTEMPT TO NOTIFY ALL PARTIES CONCERNED OF ANY CHANGES AND THE INFORMATION ON THIS SHEET SHOULD NOT BE REPRODUCED WITHOUT THEIR WRITTEN CONSENT.

1 ALL DIMENSIONS IN MILLIMETRES
REMOVE ALL SHARP EDGES

2 DO NOT JOIN MATERIAL TOGETHER
TO MAKE INDIVIDUAL ITEMS

THIRD ANGLE PROJECTION
DO NOT SCALE DRAWING

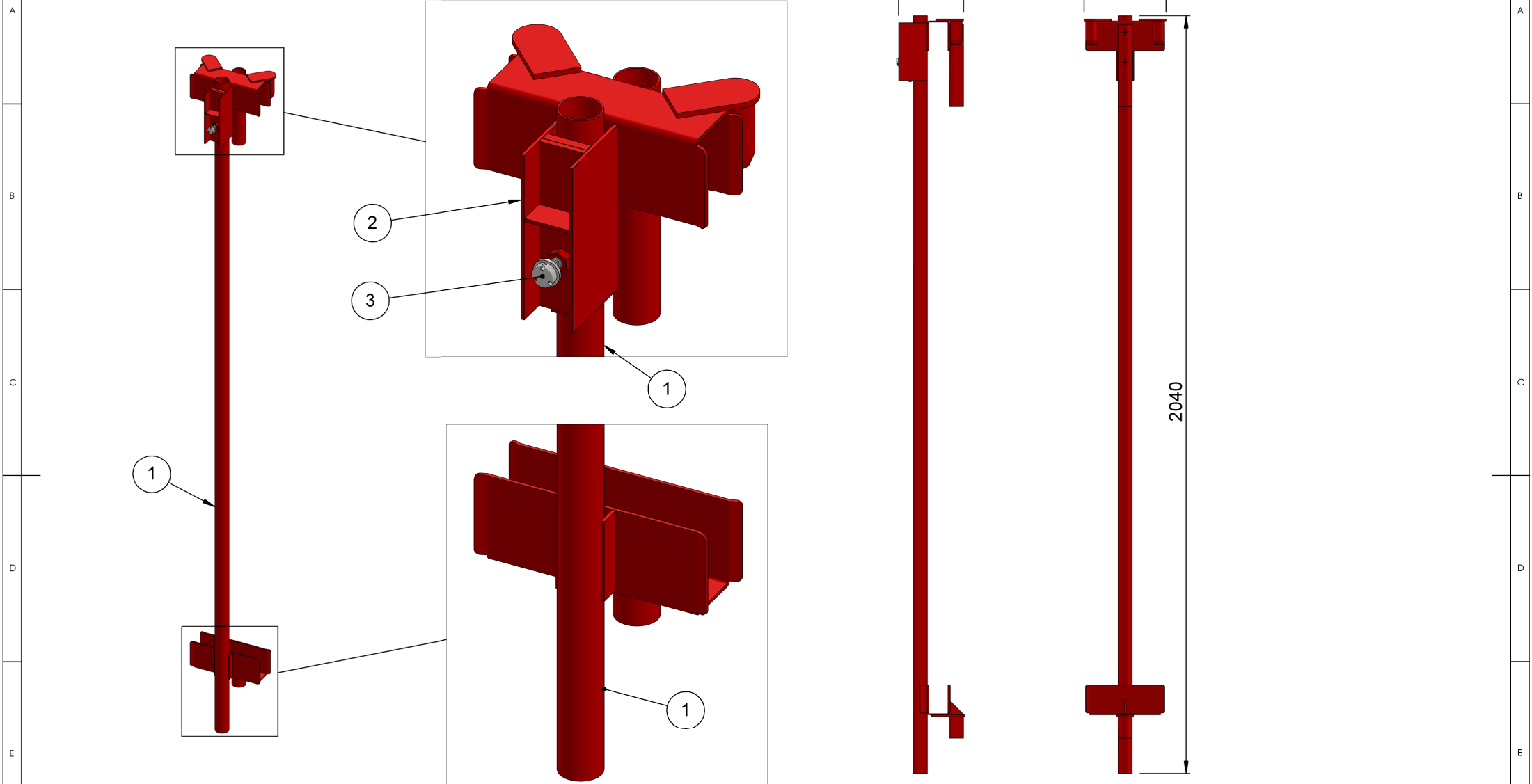

P2	17/4/19	ISSUED FOR APPROVAL	GC	.	.
P1	26/3/19	ISSUED FOR APPROVAL	GC	.	.
REV	DATE	DESCRIPTION	DRN	CHKD	APPR

ITEM No.	PART No.	DESCRIPTION	QTY
1	ZND1349-1-1	TUBE FABRICATION	1
2	ZND1349-1-2	TOP GUIDE FABRICATION	1
3	ZND1349-1-3	M10 x 30 ANTI-TAMPER BOLT	1

TOLERANCES - UNLESS STATED OTHERWISE

FABRICATION	UP TO 300mm	+/- 1mm
	UP TO 1000mm	+/- 2mm
	1001mm & ABOVE	+/- 3mm
	ANGULAR	+/- 1°
MACHINING	+/- 0.2mm	
GAUGE	+/- 10%	
WEIGHT	+/- 10% (DUE TO MATERIAL PROPERTIES & TOLERANCES)	

TITLE: **SLIDING GATE GUIDE END FABRICATION SHT 1**

NAME	SIGNATURE	DATE
DRAWN G. CRICK		26/3/19
CHK'D		
FINISH: PAINT POLYESTER POWDERCOAT. COLOUR RAL3020: GUARDS RED		

RIDGEWAY

Belfast: +44 (0) 28 90454599
 Ashbourne: +353 (01) 802 7173
 Email: info@ridgeway-online.com
 Web: www.ridgeway-online.com

Revision **P2**

1 2 3 4 5 6 7 8
 ALL DIMENSIONS IN MILLIMETRES
 REMOVE ALL SHARP EDGES
 DO NOT JOIN MATERIAL TOGETHER
 TO MAKE INDIVIDUAL ITEMS

THIRD ANGLE PROJECTION
 DO NOT SCALE DRAWING

ITEM No.	PART No.	DESCRIPTION	QTY	MATERIAL SIZE
1	ZND1349-1-1-1	TUBE	1	Ø 38.1 x 1.5 TUBE
2	ZND1349-1-1-2	GUIDE	1	SEE DETAIL
3	ZND1349-1-1-3	GUIDE RIB	2	20 x 3 FLAT x 75 Lg
4	ZND1349-1-1-4	TUBE PLATE	1	SEE DETAIL
5	ZND1349-1-1-5	TUBE PLATE RIB	1	SEE DETAIL
6	ZND1349-1-1-6	BOTTOM COUPLER TUBE	1	Ø 38.1 x 1.5 x 60 Lg TUBE
7	ZND1349-1-1-7	LOCKING PLATE	1	SEE DETAIL
8	ZND1349-1-1-8	STOP TAB	1	20 x 3 FLAT x 8 Lg

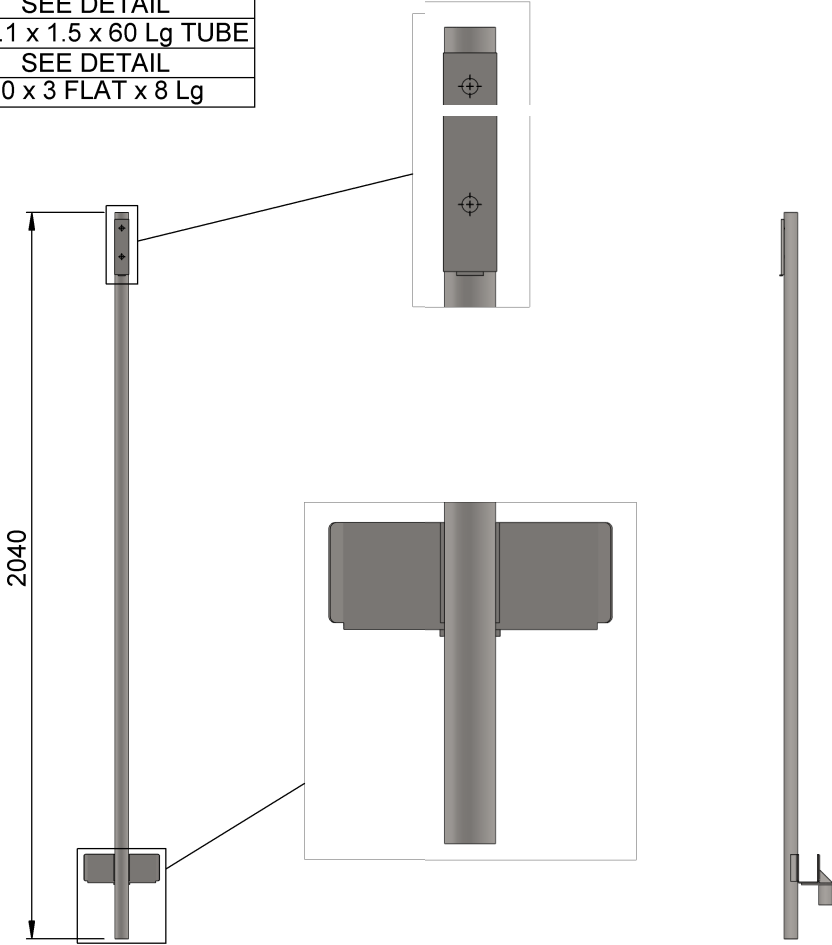
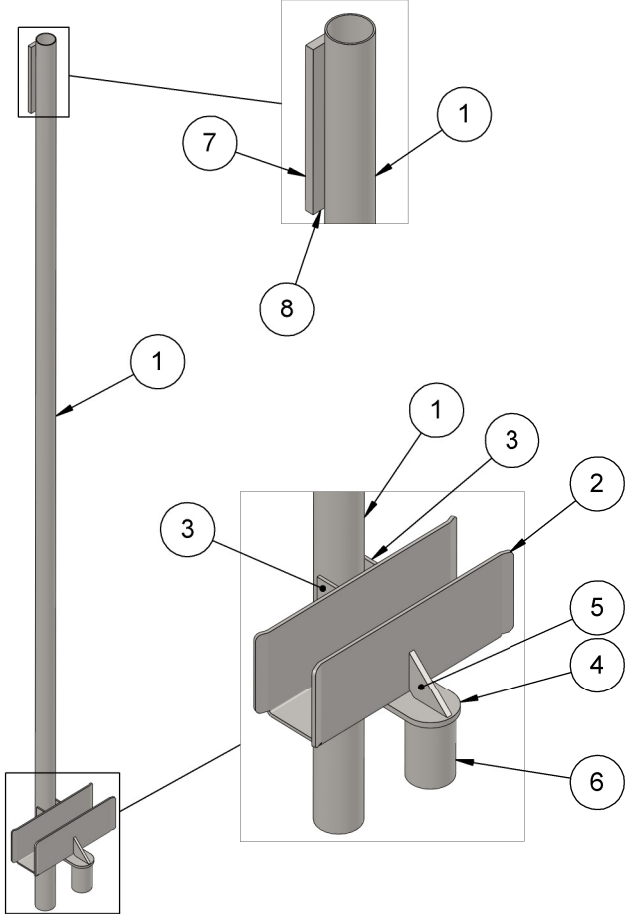

P2	17/4/19	ISSUED FOR APPROVAL	GC	.	.
P1	26/3/19	ISSUED FOR APPROVAL	GC	.	.
REV	DATE	DESCRIPTION	DRN	CHKD	APPR

TOLERANCES - UNLESS STATED OTHERWISE			TITLE: SLIDING GATE GUIDE END TUBE FABRICATION - SHT 1			
FABRICATION	UP TO 300mm	+/- 1mm	DRAWN	NAME	SIGNATURE	DATE
	UP TO 1000mm	+/- 2mm		G. CRICK		26/3/19
	1001mm & ABOVE	+/- 3mm		CHK'D		
	ANGULAR	+/- 1°	FINISH: NONE			
MACHINING	+/- 0.2mm		MATERIAL: CARBON STEEL PRE-GALVANISED			
GAUGE	+/- 10%		WEIGHT:			
WEIGHT	+/- 10% (DUE TO MATERIAL PROPERTIES & TOLERANCES)		SCALE: 1:5			

RIDGWAY

Belfast: +44 (0) 28 90454599
 Ashbourne: +353 (01) 802 7173
 Email: info@ridgway-online.com
 Web: www.ridgway-online.com

Revision **P2**

THE COMPANY RETAIN THE RIGHT TO PERIODICALLY ALTER INFORMATION WITHIN THIS DRAWING SHEET AND WILL ATTEMPT TO NOTIFY ALL PARTIES CONCERNED OF ANY CHANGES AND THE INFORMATION ON THIS SHEET SHOULD NOT BE REPRODUCED WITHOUT THEIR WRITTEN CONSENT.

1 ALL DIMENSIONS IN MILLIMETRES
REMOVE ALL SHARP EDGES

2 DO NOT JOIN MATERIAL TOGETHER
TO MAKE INDIVIDUAL ITEMS

8 THIRD ANGLE PROJECTION
DO NOT SCALE DRAWING

2040

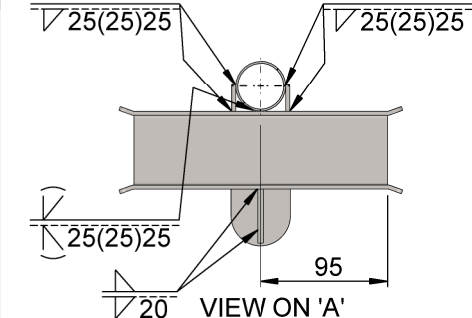
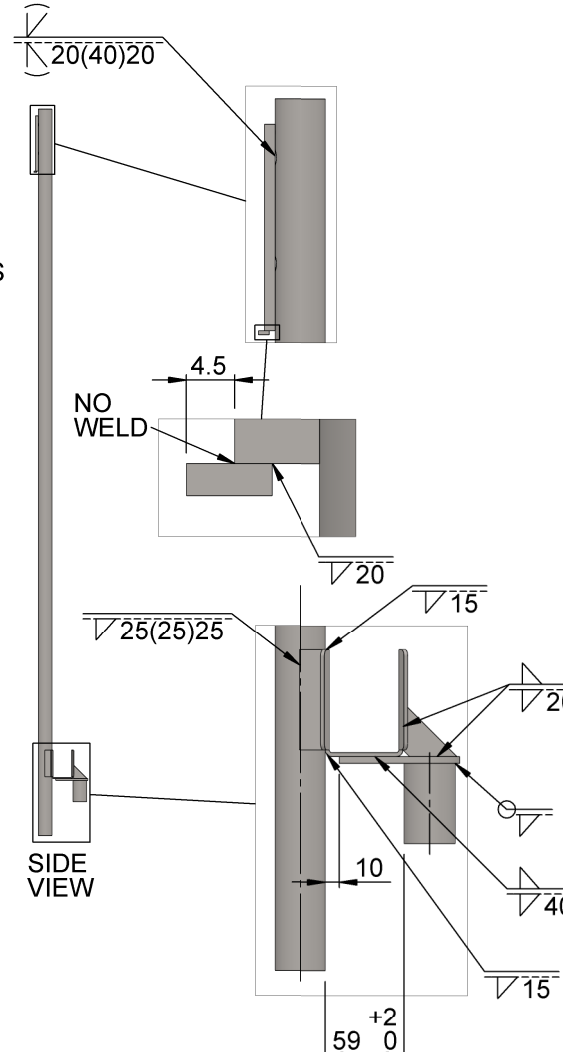
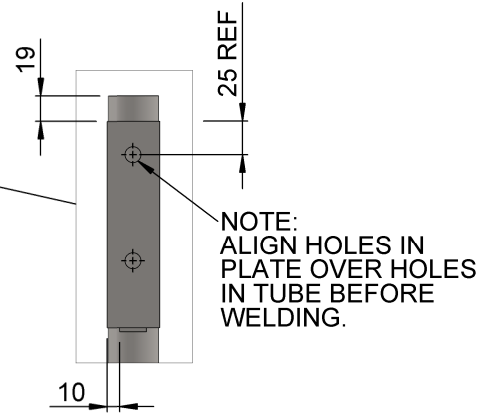

REAR VIEW

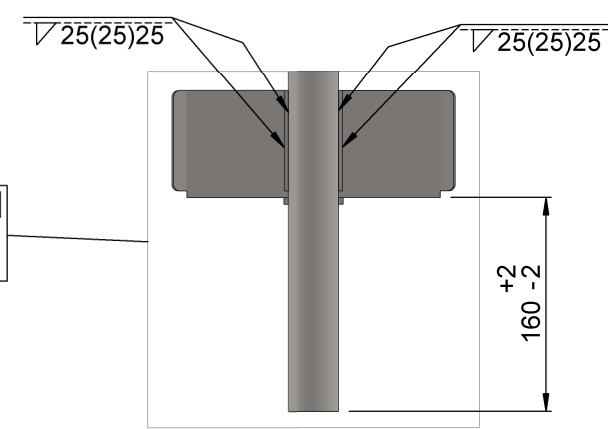

SIDE VIEW

FRONT VIEW

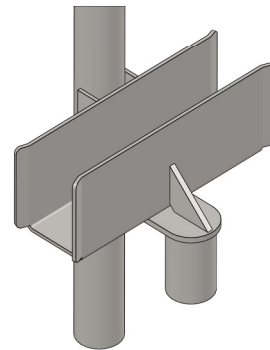
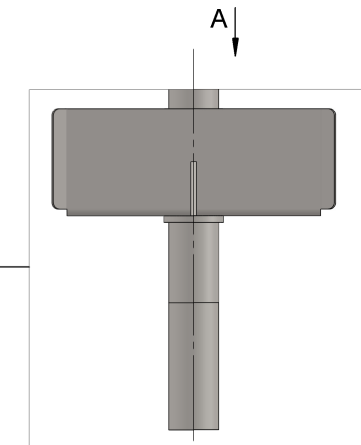

P2	17/4/19	ISSUED FOR APPROVAL	GC		
P1	26/3/19	ISSUED FOR APPROVAL	GC		
REV	DATE	DESCRIPTION	DRN	CHKD	APPR

TOLERANCES - UNLESS STATED OTHERWISE

FABRICATION	UP TO 300mm	+/- 1mm
	UP TO 1000mm	+/- 2mm
	1001mm & ABOVE	+/- 3mm
	ANGULAR	+/- 1°
MACHINING	+/- 0.2mm	
GAUGE	+/- 10%	
WEIGHT	+/- 10% (DUE TO MATERIAL PROPERTIES & TOLERANCES)	

TITLE: **SLIDING GATE GUIDE END TUBE FABRICATION - SHT 2**

NAME	SIGNATURE	DATE	MATERIAL:
G. CRICK		26/3/19	CARBON STEEL PRE-GALVANISED
CHK'D			
FINISH:			
NONE			

RIDGEWAY

Belfast: +44 (0) 28 90454599
 Ashbourne: +353 (01) 802 7173
 Email: info@ridgeway-online.com
 Web: www.ridgeway-online.com

Revision **P2**

THE COMPANY RETAIN THE RIGHT TO PERIODICALLY ALTER INFORMATION WITHIN THIS DRAWING SHEET AND WILL ATTEMPT TO NOTIFY ALL PARTIES CONCERNED OF ANY CHANGES AND THE INFORMATION ON THIS SHEET SHOULD NOT BE REPRODUCED WITHOUT THEIR WRITTEN CONSENT.

1 2
 ALL DIMENSIONS IN MILLIMETRES
 REMOVE ALL SHARP EDGES
 DO NOT JOIN MATERIAL TOGETHER
 TO MAKE INDIVIDUAL ITEMS

8
 THIRD ANGLE PROJECTION
 DO NOT SCALE DRAWING

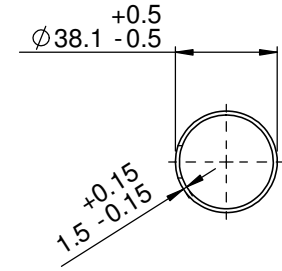
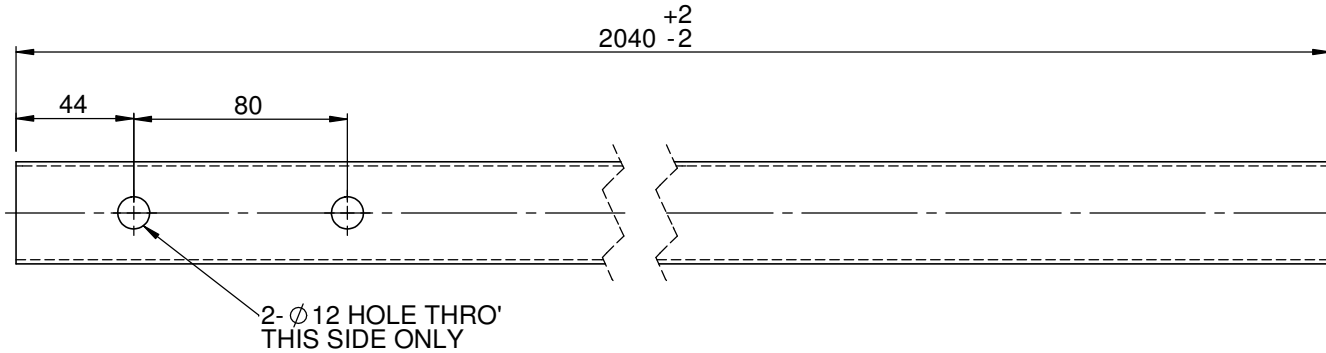

P2	17/4/19	ISSUED FOR APPROVAL	GC	.	.
P1	26/3/19	ISSUED FOR APPROVAL	GC	.	.
REV	DATE	DESCRIPTION	DRN	CHKD	APPR

TOLERANCES - UNLESS STATED OTHERWISE

FABRICATION	UP TO 300mm	+/- 1mm
	UP TO 1000mm	+/- 2mm
	1001mm & ABOVE	+/- 3mm
	ANGULAR	+/- 1°
MACHINING	+/- 0.2mm	
GAUGE	+/- 10%	
WEIGHT	+/- 10% (DUE TO MATERIAL PROPERTIES & TOLERANCES)	

TITLE: **SLIDING GATE GUIDE END TUBE**

NAME	SIGNATURE	DATE	MATERIAL:
G. CRICK		26/3/19	CARBON STEEL PRE-GALVANISED
CHK'D			
FINISH:			NONE

Belfast: +44 (0) 28 90454599
 Ashbourne: +353 (01) 802 7173
 Email: info@ridgeway-online.com
 Web: www.ridgeway-online.com

Revision
P2

THE COMPANY RETAIN THE RIGHT TO PERIODICALLY ALTER INFORMATION WITHIN THIS DRAWING SHEET AND WILL ATTEMPT TO NOTIFY ALL PARTIES CONCERNED OF ANY CHANGES AND THE INFORMATION ON THIS SHEET SHOULD NOT BE REPRODUCED WITHOUT THEIR WRITTEN CONSENT.

1
ALL DIMENSIONS IN MILLIMETRES
REMOVE ALL SHARP EDGES

2
DO NOT JOIN MATERIAL TOGETHER
TO MAKE INDIVIDUAL ITEMS

8
THIRD ANGLE PROJECTION
DO NOT SCALE DRAWING

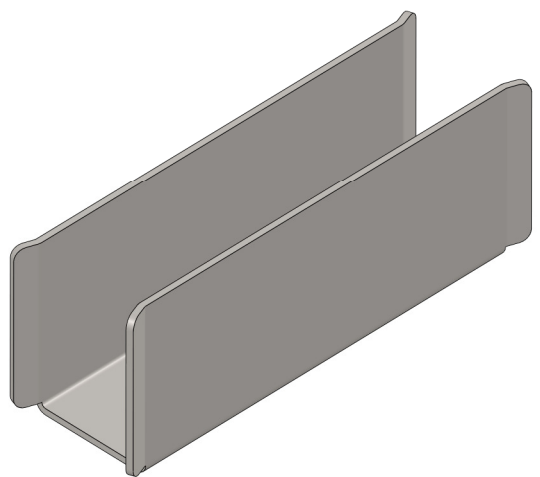
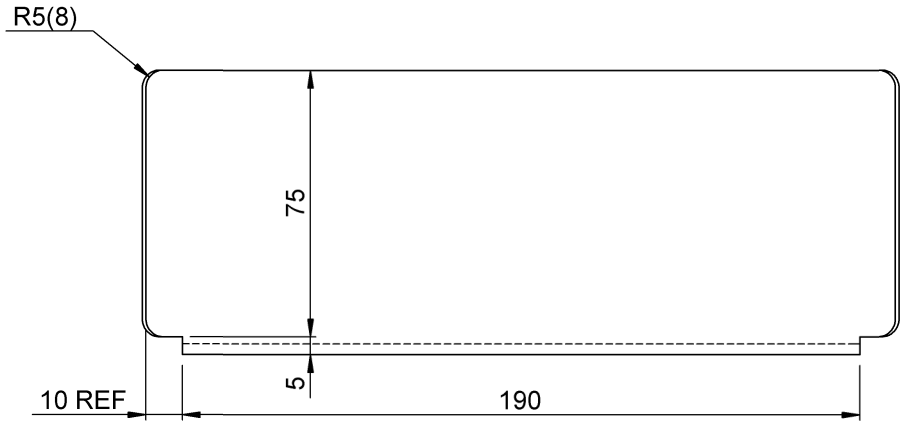
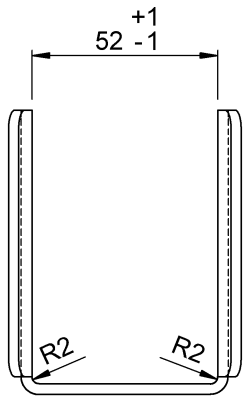
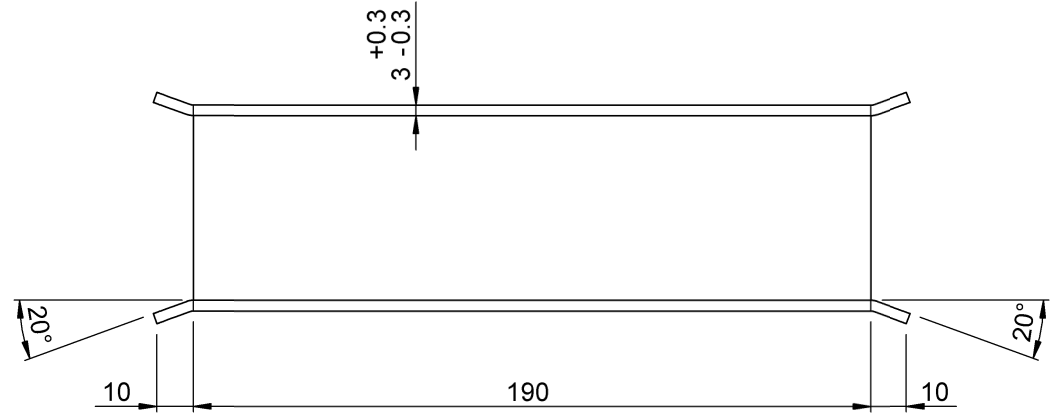

P2	17/4/19	ISSUED FOR APPROVAL	GC	.	.
P1	26/3/19	ISSUED FOR APPROVAL	GC	.	.
REV	DATE	DESCRIPTION	DRN	CHKD	APPR

TOLERANCES - UNLESS STATED OTHERWISE

FABRICATION	UP TO 300mm	+/- 1mm
	UP TO 1000mm	+/- 2mm
	1001mm & ABOVE	+/- 3mm
	ANGULAR	+/- 1°
MACHINING	+/- 0.2mm	
GAUGE	+/- 10%	
WEIGHT	+/- 10% (DUE TO MATERIAL PROPERTIES & TOLERANCES)	

TITLE: **SLIDING GATE GUIDE END GUIDE**

NAME	SIGNATURE	DATE	MATERIAL:
G. CRICK		26/3/19	CARBON STEEL PRE-GALVANISED
CHK'D			
FINISH:			
NONE			

RIDGEWAY

Belfast: +44 (0) 28 90454599
 Ashbourne: +353 (01) 802 7173
 Email: info@ridgeway-online.com
 Web: www.ridgeway-online.com

Revision
P2

THE COMPANY RETAIN THE RIGHT TO PERIODICALLY ALTER INFORMATION WITHIN THIS DRAWING SHEET AND WILL ATTEMPT TO NOTIFY ALL PARTIES CONCERNED OF ANY CHANGES AND THE INFORMATION ON THIS SHEET SHOULD NOT BE REPRODUCED WITHOUT THEIR WRITTEN CONSENT.

1 ALL DIMENSIONS IN MILLIMETRES
REMOVE ALL SHARP EDGES

2 DO NOT JOIN MATERIAL TOGETHER
TO MAKE INDIVIDUAL ITEMS

8 THIRD ANGLE PROJECTION
DO NOT SCALE DRAWING

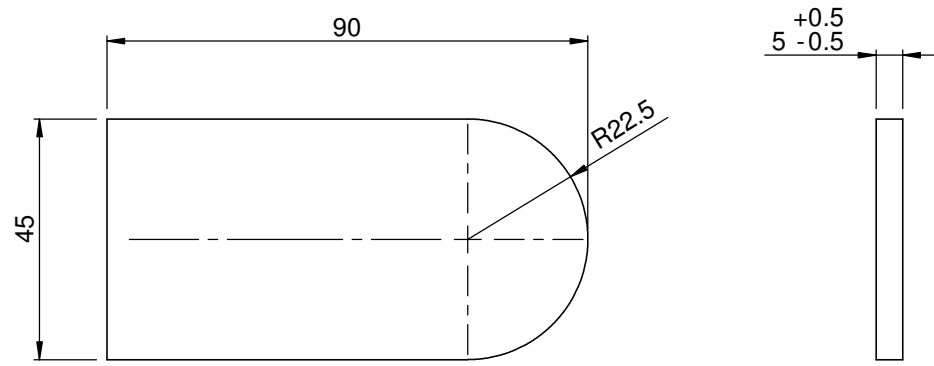

P2	17/4/19	ISSUED FOR APPROVAL	GC	.	.
P1	26/3/19	ISSUED FOR APPROVAL	GC	.	.
REV	DATE	DESCRIPTION	DRN	CHKD	APPR

TOLERANCES - UNLESS STATED OTHERWISE

FABRICATION	UP TO 300mm	+/- 1mm
	UP TO 1000mm	+/- 2mm
	1001mm & ABOVE	+/- 3mm
	ANGULAR	+/- 1°
MACHINING	+/- 0.2mm	
GAUGE	+/- 10%	
WEIGHT	+/- 10% (DUE TO MATERIAL PROPERTIES & TOLERANCES)	

TITLE: **SLIDING GATE GUIDE END
BOTTOM COUPLER TUBE PLATE**

NAME	SIGNATURE	DATE	MATERIAL:
G. CRICK		26/3/19	CARBON STEEL PRE-GALVANISED
CHK'D			
FINISH:			NONE



Belfast: +44 (0) 28 90454599
 Ashbourne: +353 (01) 802 7173
 Email: info@ridgeway-online.com
 Web: www.ridgeway-online.com

Revision **P2**

THE COMPANY RETAIN THE RIGHT TO PERIODICALLY ALTER INFORMATION WITHIN THIS DRAWING SHEET AND WILL ATTEMPT TO NOTIFY ALL PARTIES CONCERNED OF ANY CHANGES AND THE INFORMATION ON THIS SHEET SHOULD NOT BE REPRODUCED WITHOUT THEIR WRITTEN CONSENT.

1
ALL DIMENSIONS IN MILLIMETRES
REMOVE ALL SHARP EDGES

2
DO NOT JOIN MATERIAL TOGETHER
TO MAKE INDIVIDUAL ITEMS

8
THIRD ANGLE PROJECTION
DO NOT SCALE DRAWING

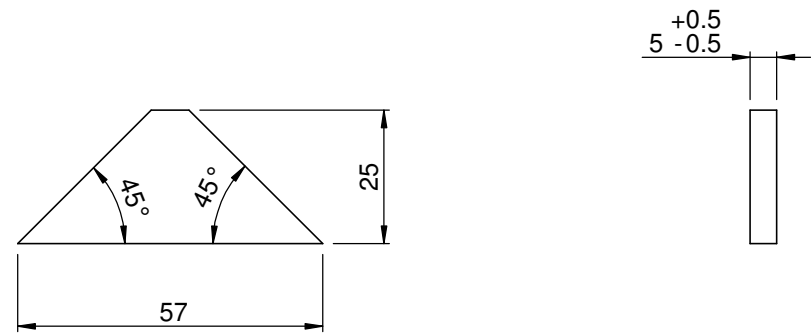

P2	17/4/19	ISSUED FOR APPROVAL	GC	.	.
P1	26/3/19	ISSUED FOR APPROVAL	GC	.	.
REV	DATE	DESCRIPTION	DRN	CHKD	APPR

TOLERANCES - UNLESS STATED OTHERWISE

FABRICATION	UP TO 300mm	+/- 1mm
	UP TO 1000mm	+/- 2mm
	1001mm & ABOVE	+/- 3mm
	ANGULAR	+/- 1°
MACHINING	+/- 0.2mm	
GAUGE	+/- 10%	
WEIGHT	+/- 10% (DUE TO MATERIAL PROPERTIES & TOLERANCES)	

TITLE: **SLIDING GATE GUIDE END TUBE PLATE RIB**

NAME	SIGNATURE	DATE	MATERIAL:
G. CRICK		26/3/19	CARBON STEEL PRE-GALVANISED
FINISH:	NONE		

RIDGEWAY

Belfast: +44 (0) 28 90454599
 Ashbourne: +353 (01) 802 7173
 Email: info@ridgeway-online.com
 Web: www.ridgeway-online.com

Revision **P2**

THE COMPANY RETAIN THE RIGHT TO PERIODICALLY ALTER INFORMATION WITHIN THIS DRAWING SHEET AND WILL ATTEMPT TO NOTIFY ALL PARTIES CONCERNED OF ANY CHANGES AND THE INFORMATION ON THIS SHEET SHOULD NOT BE REPRODUCED WITHOUT THEIR WRITTEN CONSENT.

1 ALL DIMENSIONS IN MILLIMETRES
REMOVE ALL SHARP EDGES

2 DO NOT JOIN MATERIAL TOGETHER
TO MAKE INDIVIDUAL ITEMS

THIRD ANGLE PROJECTION
DO NOT SCALE DRAWING

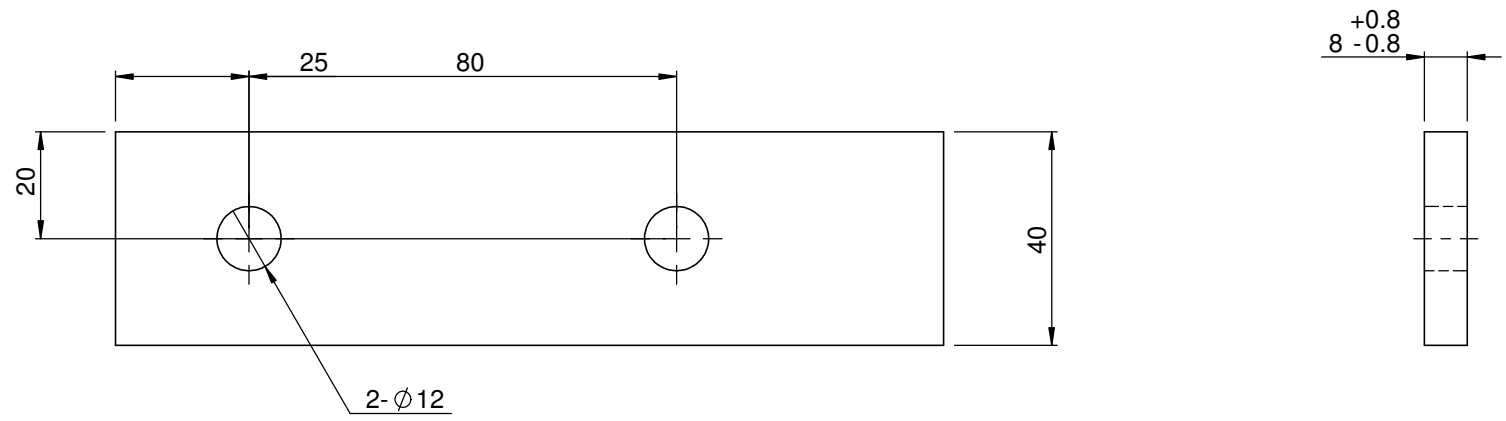

P2	18/4/19	ISSUED FOR APPROVAL	GC	.	.
P1	26/3/19	ISSUED FOR APPROVAL	GC	.	.
REV	DATE	DESCRIPTION	DRN	CHKD	APPR

TOLERANCES - UNLESS STATED OTHERWISE			TITLE: SLIDING GATE GUIDE END LOCKING PLATE		
FABRICATION	UP TO 300mm	+/- 1mm	DRAWN	NAME	G. CRICK
	UP TO 1000mm	+/- 2mm		SIGNATURE	
	1001mm & ABOVE	+/- 3mm		DATE	26/3/19
MACHINING	ANGULAR	+/- 1°	CHK'D		
GAUGE	+/- 10%		FINISH: NONE		
WEIGHT	+/- 10% (DUE TO MATERIAL PROPERTIES & TOLERANCES)		MATERIAL: CARBON STEEL PRE-GALVANISED		

RIDGEWAY

Belfast: +44 (0) 28 90454599
 Ashbourne: +353 (01) 802 7173
 Email: info@ridgeway-online.com
 Web: www.ridgeway-online.com

Revision **P2**

THE COMPANY RETAIN THE RIGHT TO PERIODICALLY ALTER INFORMATION WITHIN THIS DRAWING SHEET AND WILL ATTEMPT TO NOTIFY ALL PARTIES CONCERNED OF ANY CHANGES AND THE INFORMATION ON THIS SHEET SHOULD NOT BE REPRODUCED WITHOUT THEIR WRITTEN CONSENT.

1
ALL DIMENSIONS IN MILLIMETRES
REMOVE ALL SHARP EDGES

2
DO NOT JOIN MATERIAL TOGETHER
TO MAKE INDIVIDUAL ITEMS

8
THIRD ANGLE PROJECTION
DO NOT SCALE DRAWING

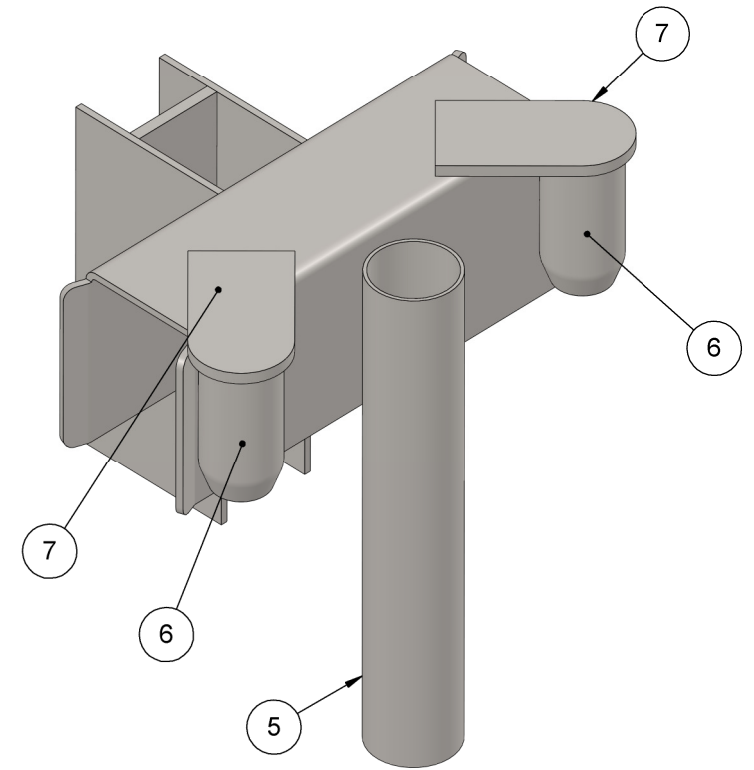
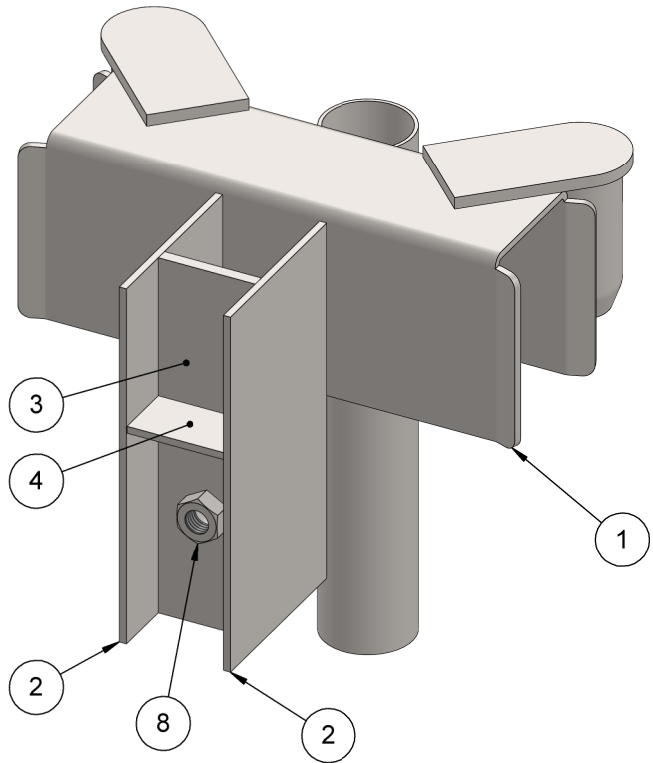

ITEM No.	PART No.	DESCRIPTION	QTY	MATERIAL SIZE
1	ZND1349-1-1-2	GUIDE	1	SEE DETAIL
2	ZND1349-1-2-2	SIDE PLATE	2	155 x 3 x 77 PLATE
3	ZND1349-1-2-3	BACK PLATE	1	SEE DETAIL
4	ZND1349-1-2-4	RIB	1	25 x 3 FLAT x 41 Lg
5	ZND1349-1-2-5	TOP COUPLER TUBE	1	Ø 38.1 x 1.5 TUBE x 220 Lg
6	ZND1349-1-2-6	PANEL SPIGOT	2	SEE DETAIL
7	ZND1349-1-2-7	SPIGOT PLATE	2	SEE DETAIL
8		M10 NUT	1	

REV	DATE	DESCRIPTION	DRN	CHKD	APPR
P2	18/4/19	ISSUED FOR APPROVAL	GC	.	.
P1	26/3/19	ISSUED FOR APPROVAL	GC	.	.

TOLERANCES - UNLESS STATED OTHERWISE

FABRICATION	UP TO 300mm	+/- 1mm
	UP TO 1000mm	+/- 2mm
	1001mm & ABOVE	+/- 3mm
	ANGULAR	+/- 1°
MACHINING	+/- 0.2mm	
GAUGE	+/- 10%	
WEIGHT	+/- 10% (DUE TO MATERIAL PROPERTIES & TOLERANCES)	

TITLE: **SLIDING GATE GUIDE END TOP GUIDE FAB SHT 1**

NAME	SIGNATURE	DATE
DRAWN G. CRICK		26/3/19
CHK'D		
FINISH: NONE		

MATERIAL: CARBON STEEL PRE-GALVANISED



Belfast: +44 (0) 28 90454599
 Ashbourne: +353 (01) 802 7173
 Email: info@ridgeway-online.com
 Web: www.ridgeway-online.com

Revision
P2

THE COMPANY RETAIN THE RIGHT TO PERIODICALLY ALTER INFORMATION WITHIN THIS DRAWING SHEET AND WILL ATTEMPT TO NOTIFY ALL PARTIES CONCERNED OF ANY CHANGES AND THE INFORMATION ON THIS SHEET SHOULD NOT BE REPRODUCED WITHOUT THEIR WRITTEN CONSENT.

1 ALL DIMENSIONS IN MILLIMETRES
REMOVE ALL SHARP EDGES

2 DO NOT JOIN MATERIAL TOGETHER
TO MAKE INDIVIDUAL ITEMS

8 THIRD ANGLE PROJECTION
DO NOT SCALE DRAWING

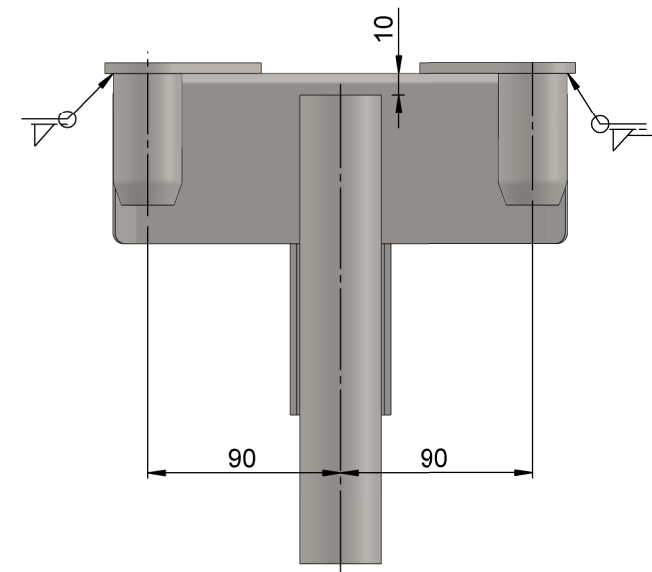
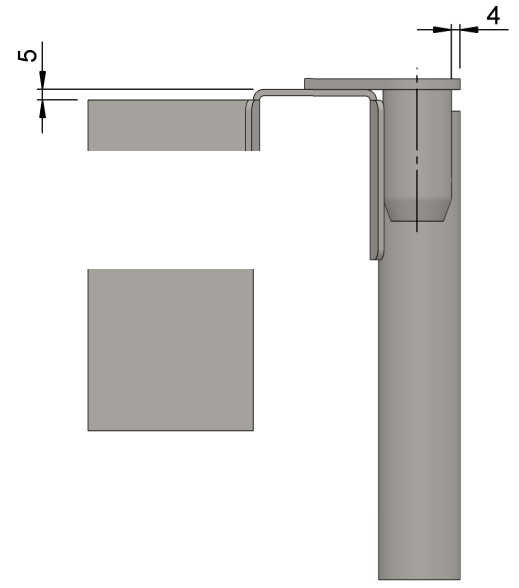
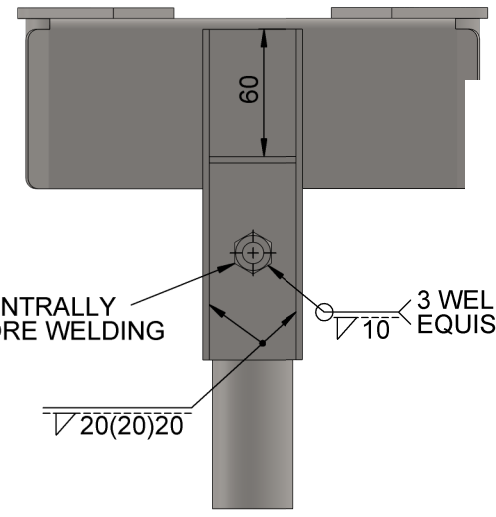
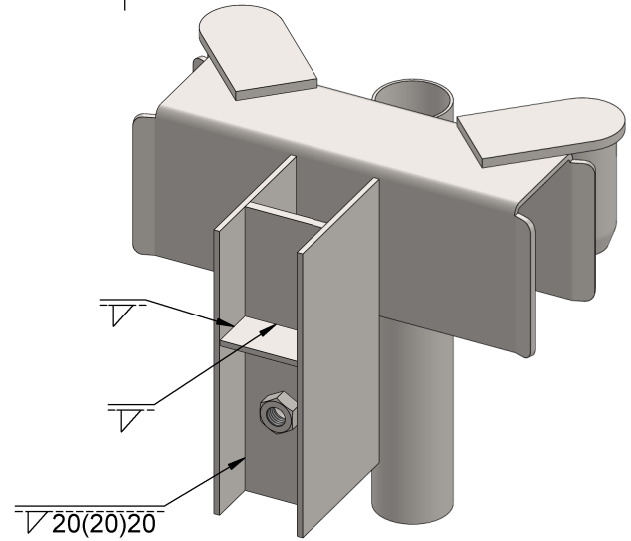
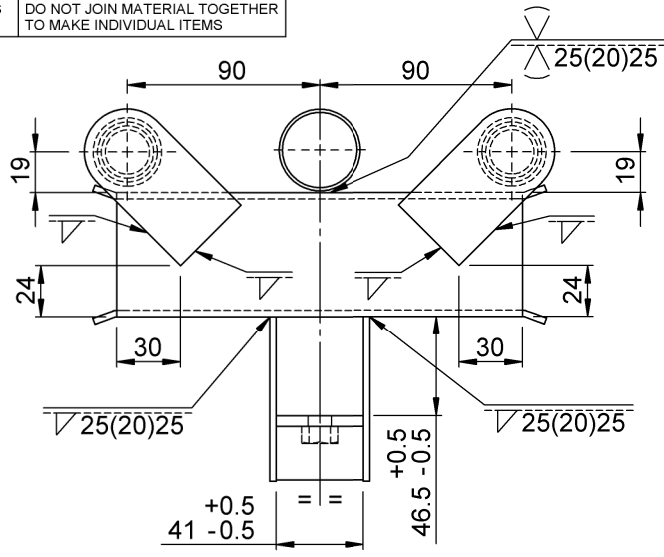

POSITION NUT CENTRALLY
OVER HOLE BEFORE WELDING

3 WELDS
EQUISPACED

P2	18/4/19	ISSUED FOR APPROVAL	GC	.	.
P1	26/3/19	ISSUED FOR APPROVAL	GC	.	.
REV	DATE	DESCRIPTION	DRN	CHKD	APPR

TOLERANCES - UNLESS STATED OTHERWISE		
FABRICATION	UP TO 300mm	+/- 1mm
	UP TO 1000mm	+/- 2mm
	1001mm & ABOVE	+/- 3mm
	ANGULAR	+/- 1°
MACHINING	+/- 0.2mm	
GAUGE	+/- 10%	
WEIGHT	+/- 10% (DUE TO MATERIAL PROPERTIES & TOLERANCES)	

TITLE: SLIDING GATE GUIDE END TOP GUIDE FAB SHT 2			
NAME	SIGNATURE	DATE	MATERIAL:
G. CRICK		26/3/19	CARBON STEEL PRE-GALVANISED
CHK'D			
FINISH:			
NONE			

RIDGWAY

Belfast: +44 (0) 28 90454599
 Ashbourne: +353 (01) 802 7173
 Email: info@ridgway-online.com
 Web: www.ridgway-online.com

Revision
P2

THE COMPANY RETAIN THE RIGHT TO PERIODICALLY ALTER INFORMATION WITHIN THIS DRAWING SHEET AND WILL ATTEMPT TO NOTIFY ALL PARTIES CONCERNED OF ANY CHANGES AND THE INFORMATION ON THIS SHEET SHOULD NOT BE REPRODUCED WITHOUT THEIR WRITTEN CONSENT.

1 ALL DIMENSIONS IN MILLIMETRES
REMOVE ALL SHARP EDGES

2 DO NOT JOIN MATERIAL TOGETHER
TO MAKE INDIVIDUAL ITEMS

8 THIRD ANGLE PROJECTION
DO NOT SCALE DRAWING

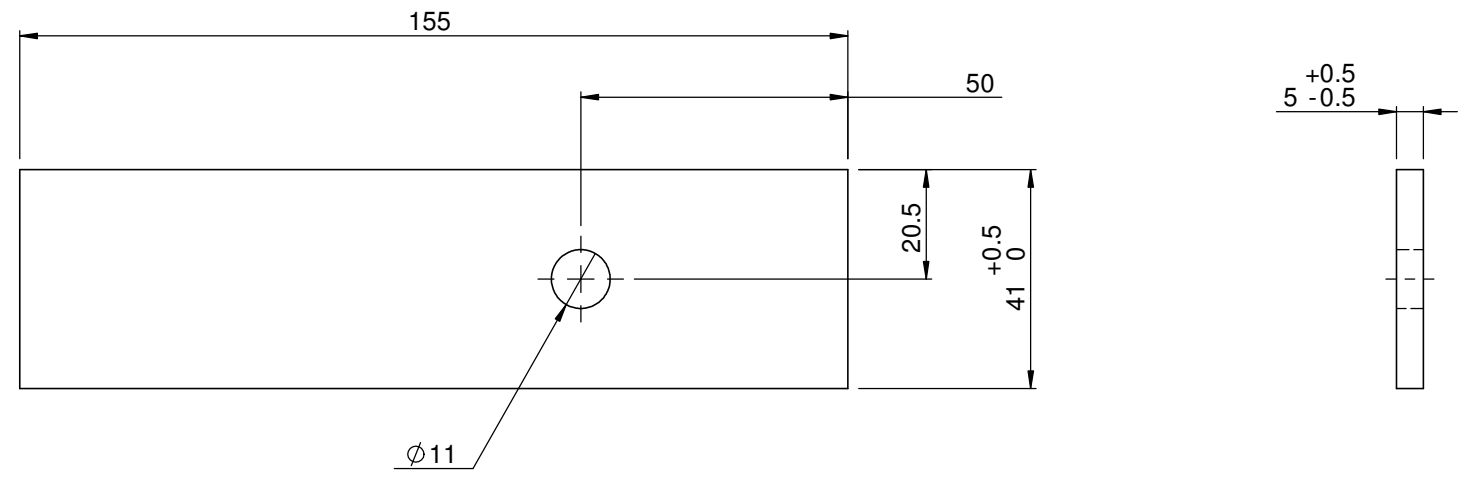

P2	18/4/19	ISSUED FOR APPROVAL	GC	.	.
P1	26/3/19	ISSUED FOR APPROVAL	GC	.	.
REV	DATE	DESCRIPTION	DRN	CHKD	APPR

TOLERANCES - UNLESS STATED OTHERWISE

FABRICATION	UP TO 300mm	+/- 1mm
	UP TO 1000mm	+/- 2mm
	1001mm & ABOVE	+/- 3mm
	ANGULAR	+/- 1°
MACHINING	+/- 0.2mm	
GAUGE	+/- 10%	
WEIGHT	+/- 10% (DUE TO MATERIAL PROPERTIES & TOLERANCES)	

TITLE: **SLIDING GATE GUIDE END TOP GUIDE BACK PLATE**

NAME	SIGNATURE	DATE
G. CRICK		26/3/19
CHK'D		
FINISH:	NONE	

MATERIAL: **CARBON STEEL PRE-GALVANISED**

RIDGEWAY

Belfast: +44 (0) 28 90454599
 Ashbourne: +353 (01) 802 7173
 Email: info@ridgeway-online.com
 Web: www.ridgeway-online.com

Revision **P2**

THE COMPANY RETAIN THE RIGHT TO PERIODICALLY ALTER INFORMATION WITHIN THIS DRAWING SHEET AND WILL ATTEMPT TO NOTIFY ALL PARTIES CONCERNED OF ANY CHANGES AND THE INFORMATION ON THIS SHEET SHOULD NOT BE REPRODUCED WITHOUT THEIR WRITTEN CONSENT.

1
ALL DIMENSIONS IN MILLIMETRES
REMOVE ALL SHARP EDGES

2
DO NOT JOIN MATERIAL TOGETHER
TO MAKE INDIVIDUAL ITEMS

8
THIRD ANGLE PROJECTION
DO NOT SCALE DRAWING

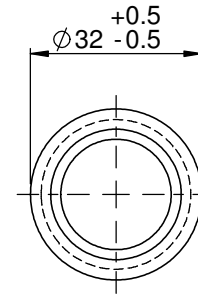
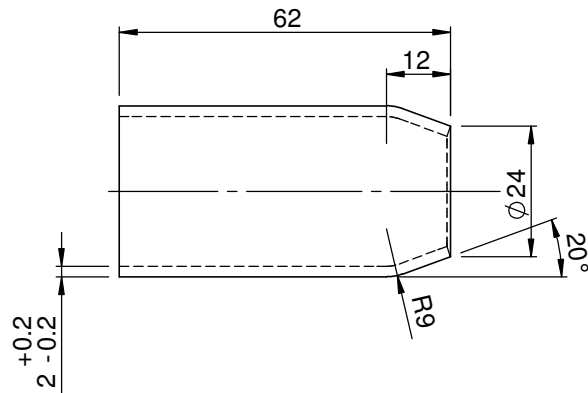

P2	18/4/19	ISSUED FOR APPROVAL	GC		
P1	26/3/19	ISSUED FOR APPROVAL	GC		
REV	DATE	DESCRIPTION	DRN	CHKD	APPR

TOLERANCES - UNLESS STATED OTHERWISE		
FABRICATION	UP TO 300mm	+/- 1mm
	UP TO 1000mm	+/- 2mm
	1001mm & ABOVE	+/- 3mm
	ANGULAR	+/- 1°
MACHINING	+/- 0.2mm	
GAUGE	+/- 10%	
WEIGHT	+/- 10% (DUE TO MATERIAL PROPERTIES & TOLERANCES)	

TITLE: SLIDING GATE GUIDE END TOP GUIDE PANEL SPIGOT			
NAME	SIGNATURE	DATE	MATERIAL:
G. CRICK		26/3/19	CARBON STEEL PRE-GALVANISED
CHK'D			
FINISH: NONE			



Belfast: +44 (0) 28 90454599
 Ashbourne: +353 (01) 802 7173
 Email: info@ridgeway-online.com
 Web: www.ridgeway-online.com

Revision
P2

THE COMPANY RETAIN THE RIGHT TO PERIODICALLY ALTER INFORMATION WITHIN THIS DRAWING SHEET AND WILL ATTEMPT TO NOTIFY ALL PARTIES CONCERNED OF ANY CHANGES AND THE INFORMATION ON THIS SHEET SHOULD NOT BE REPRODUCED WITHOUT THEIR WRITTEN CONSENT.

1
ALL DIMENSIONS IN MILLIMETRES
REMOVE ALL SHARP EDGES

2
DO NOT JOIN MATERIAL TOGETHER
TO MAKE INDIVIDUAL ITEMS

8
THIRD ANGLE PROJECTION
DO NOT SCALE DRAWING

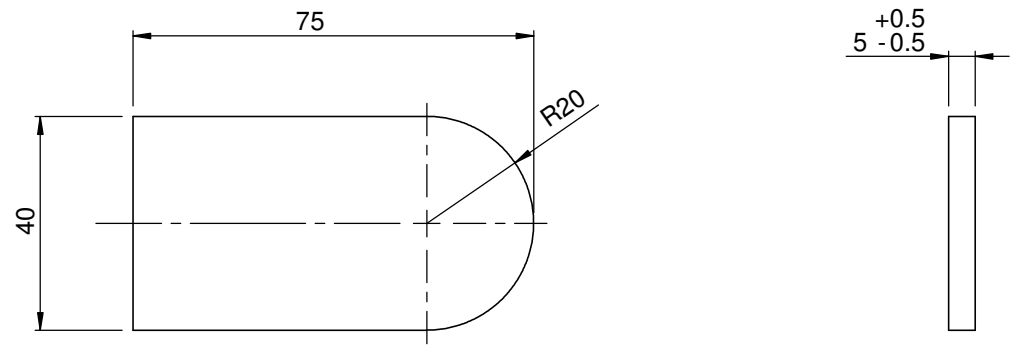

P2	18/4/19	ISSUED FOR APPROVAL	GC		
P1	26/3/19	ISSUED FOR APPROVAL	GC		
REV	DATE	DESCRIPTION	DRN	CHKD	APPR

TOLERANCES - UNLESS STATED OTHERWISE

FABRICATION	UP TO 300mm	+/- 1mm
	UP TO 1000mm	+/- 2mm
	1001mm & ABOVE	+/- 3mm
	ANGULAR	+/- 1°
MACHINING	+/- 0.2mm	
GAUGE	+/- 10%	
WEIGHT	+/- 10% (DUE TO MATERIAL PROPERTIES & TOLERANCES)	

TITLE: **SLIDING GATE GUIDE END TOP GUIDE SPIGOT PLATE**

NAME	SIGNATURE	DATE	MATERIAL:
G. CRICK		26/3/19	CARBON STEEL PRE-GALVANISED
CHK'D			
FINISH:			NONE

RIDGWAY

Belfast: +44 (0) 28 90454599
 Ashbourne: +353 (01) 802 7173
 Email: info@ridgeway-online.com
 Web: www.ridgeway-online.com

Revision **P2**

THE COMPANY RETAIN THE RIGHT TO PERIODICALLY ALTER INFORMATION WITHIN THIS DRAWING SHEET AND WILL ATTEMPT TO NOTIFY ALL PARTIES CONCERNED OF ANY CHANGES AND THE INFORMATION ON THIS SHEET SHOULD NOT BE REPRODUCED WITHOUT THEIR WRITTEN CONSENT.

1
ALL DIMENSIONS IN MILLIMETRES
REMOVE ALL SHARP EDGES

2
DO NOT JOIN MATERIAL TOGETHER
TO MAKE INDIVIDUAL ITEMS

8
THIRD ANGLE PROJECTION
DO NOT SCALE DRAWING

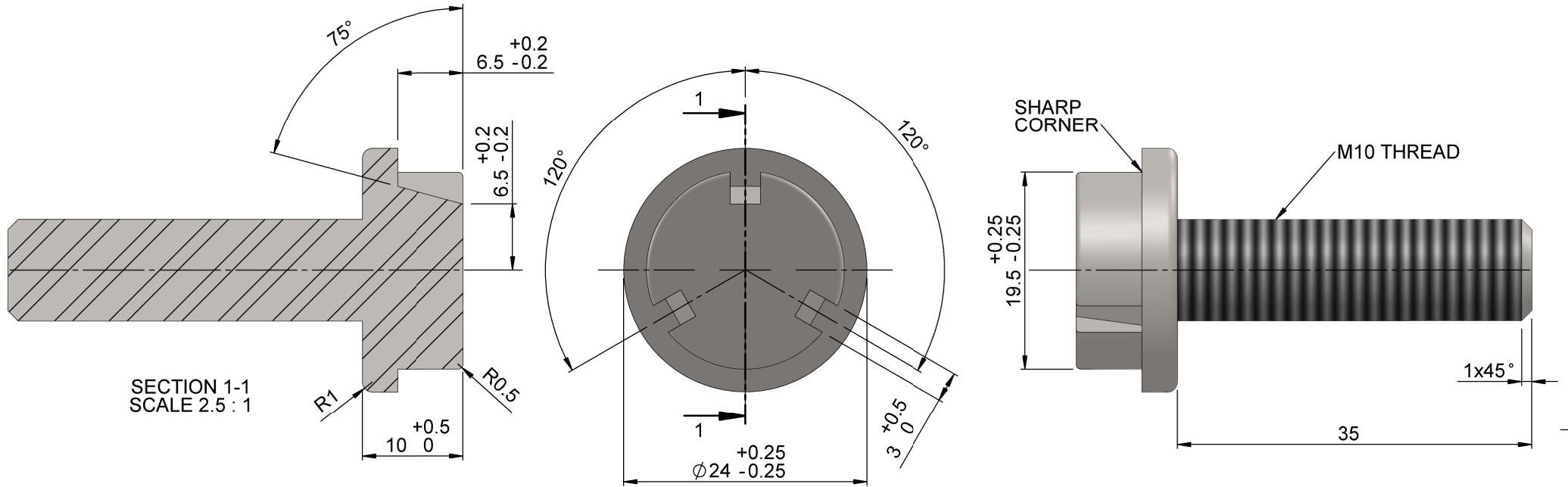

SECTION 1-1
SCALE 2.5 : 1

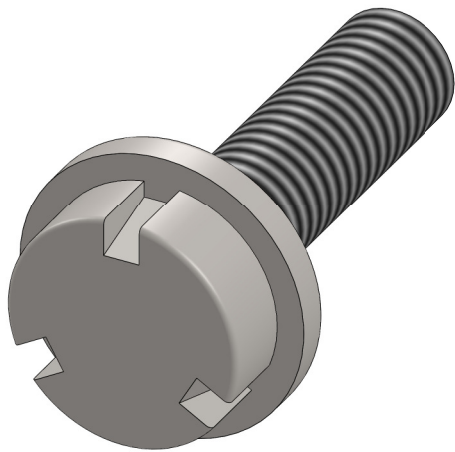

P2	17/4/19	ISSUED FOR APPROVAL	GC	.	.
P1	26/3/19	ISSUED FOR APPROVAL	GC	.	.
REV	DATE	DESCRIPTION	DRN	CHKD	APPR

TOLERANCES - UNLESS STATED OTHERWISE		
FABRICATION	UP TO 300mm	+/- 1mm
	UP TO 1000mm	+/- 2mm
	1001mm & ABOVE	+/- 3mm
	ANGULAR	+/- 1°
MACHINING	+/- 0.2mm	
GAUGE	+/- 10%	
WEIGHT	+/- 10% (DUE TO MATERIAL PROPERTIES & TOLERANCES)	

TITLE: SLIDING GATE GUIDE END ANTI-TAMPER BOLT			
NAME	SIGNATURE	DATE	MATERIAL:
G. CRICK		26/3/19	CARBON STEEL GRADE S275
CHK'D			
FINISH:			
ELECTRO-GALVANISE			



Belfast: +44 (0) 28 90454599
Ashbourne: +353 (01) 802 7173
Email: info@ridgeway-online.com
Web: www.ridgeway-online.com

Revision
P2

THE COMPANY RETAIN THE RIGHT TO PERIODICALLY ALTER INFORMATION WITHIN THIS DRAWING SHEET AND WILL ATTEMPT TO NOTIFY ALL PARTIES CONCERNED OF ANY CHANGES AND THE INFORMATION ON THIS SHEET SHOULD NOT BE REPRODUCED WITHOUT THEIR WRITTEN CONSENT.

1 ALL DIMENSIONS IN MILLIMETRES
REMOVE ALL SHARP EDGES

2 DO NOT JOIN MATERIAL TOGETHER
TO MAKE INDIVIDUAL ITEMS

THIRD ANGLE PROJECTION
DO NOT SCALE DRAWING

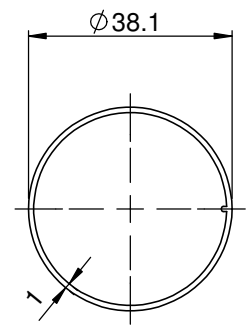
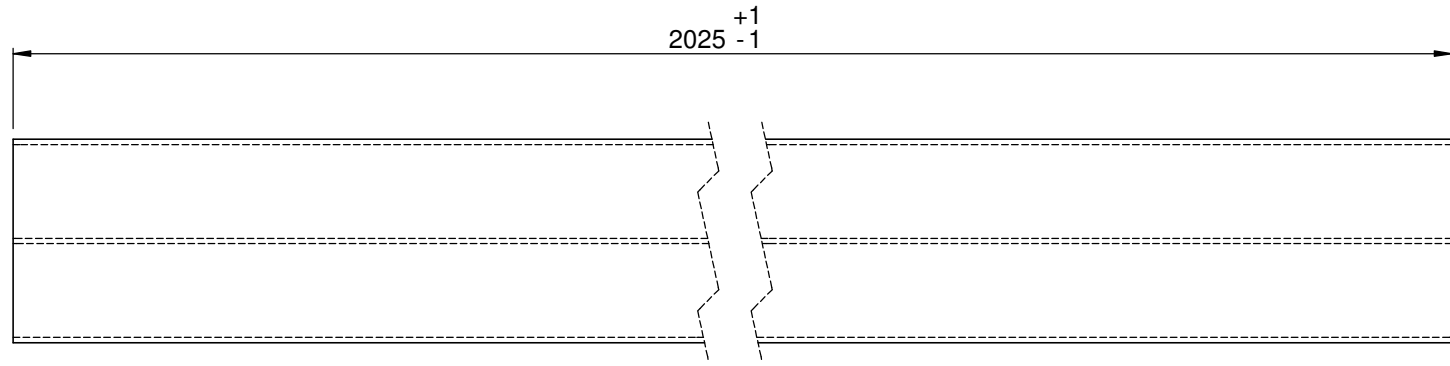

1	24/3/17	ISSUED FOR MANUFACTURE	GC	.	.
0	20/2/17	ISSUED FOR MANUFACTURE	GC	.	.
REV	DATE	DESCRIPTION	DRN	CHKD	APPR

TOLERANCES - UNLESS STATED OTHERWISE

UNTOLERANCED DIMENSIONS	+/- 2mm	
CUTTING LENGTHS	+/- 2mm	
FABRICATION	UP TO 300mm	+/- 1mm
	UP TO 1000mm	+/- 2mm
	1001mm & ABOVE	+/- 3mm
	ANGULAR	+/- 1°
MACHINING	+/- 0.2mm	
GAUGE	+/- 10%	
WEIGHT	+/- 10% (DUE TO MATERIAL PROPERTIES & TOLERANCES)	

TITLE: **38.1mm x 1 x 2025mm
TUBE PRE-GALV**

NAME	SIGNATURE	DATE
G. CRICK		20/2/17
CHK'D		
FINISH: NONE		

MATERIAL: **CARBON STEEL
PRE-GALVANISED**



Belfast: +44 (0) 28 90454599
 Ashbourne: +353 (01) 802 7173
 Email: info@ridgeway-online.com
 Web: www.ridgeway-online.com

Revision
0

WAS 29051510

THE COMPANY RETAIN THE RIGHT TO PERIODICALLY ALTER INFORMATION WITHIN THIS DRAWING SHEET AND WILL ATTEMPT TO NOTIFY ALL PARTIES CONCERNED OF ANY CHANGES AND THE INFORMATION ON THIS SHEET SHOULD NOT BE REPRODUCED WITHOUT THEIR WRITTEN CONSENT.

1 ALL DIMENSIONS IN MILLIMETRES
REMOVE ALL SHARP EDGES

2 DO NOT JOIN MATERIAL TOGETHER
TO MAKE INDIVIDUAL ITEMS

8 THIRD ANGLE PROJECTION
DO NOT SCALE DRAWING

NOTE:
ALL ITEMS ARE TO BE PAINTED
INDIVIDUALLY. ALL SCREW THREADS
ARE TO BE COVERED BEFORE PAINTING.
COUPLERS ARE NOT TO BE PAINTED.

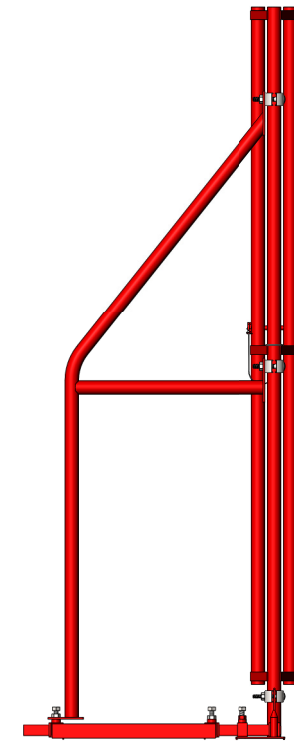
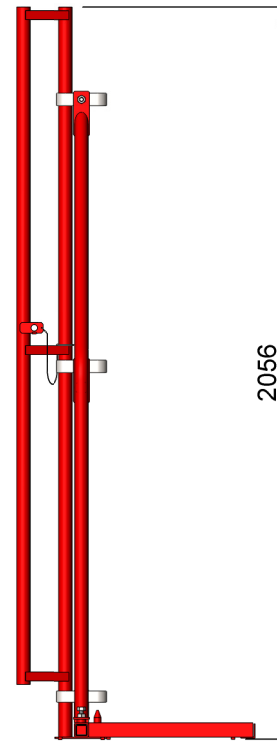
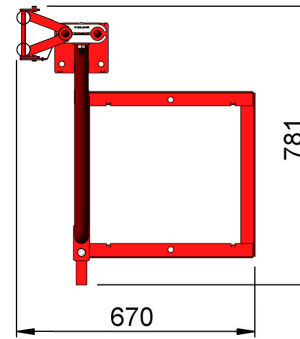
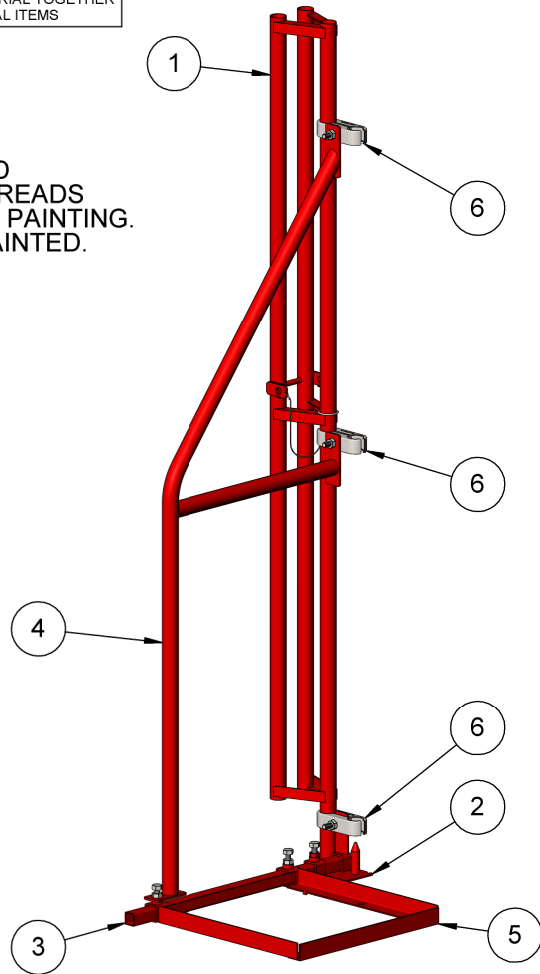

ITEM No.	PART No.	DESCRIPTION	QTY
1	ZND1349-2	LOCKING END FAB	1
2	16552096	WINDBREAKER ZERO-TRIP FOOT	1
3	16552098	WINDBREAKER BOTTOM TUBE - REDUCED	1
4	16552099	WINDBREAKER STABILISER - REDUCED	1
5	16552100	WINDBREAKER BLOCK TRAY	1
6	08551330	HD FENCE COUPLER - GRIPPER	3

REV	DATE	DESCRIPTION	DRN	CHKD	APPR
P2	17/4/19	ISSUED FOR APPROVAL	GC	.	.
P1	26/3/19	ISSUED FOR APPROVAL	GC	.	.

TOLERANCES - UNLESS STATED OTHERWISE

FABRICATION	UP TO 300mm	+/- 1mm
	UP TO 1000mm	+/- 2mm
	1001mm & ABOVE	+/- 3mm
	ANGULAR	+/- 1°
MACHINING	+/- 0.2mm	
GAUGE	+/- 10%	
WEIGHT	+/- 10% (DUE TO MATERIAL PROPERTIES & TOLERANCES)	

TITLE: **SLIDING GATE LOCKING END + STABILISER**

NAME	SIGNATURE	DATE
DRAWN G. CRICK		26/3/19
CHK'D		

FINISH: PAINT POLYESTER POWDERCOAT. COLOUR RAL3020: GUARDS RED

RIDGEWAY

Belfast: +44 (0) 28 90454599
 Ashbourne: +353 (01) 802 7173
 Email: info@ridgeway-online.com
 Web: www.ridgeway-online.com

Revision **P2**

THE COMPANY RETAIN THE RIGHT TO PERIODICALLY ALTER INFORMATION WITHIN THIS DRAWING SHEET AND WILL ATTEMPT TO NOTIFY ALL PARTIES CONCERNED OF ANY CHANGES AND THE INFORMATION ON THIS SHEET SHOULD NOT BE REPRODUCED WITHOUT THEIR WRITTEN CONSENT.

1 ALL DIMENSIONS IN MILLIMETRES
REMOVE ALL SHARP EDGES

2 DO NOT JOIN MATERIAL TOGETHER
TO MAKE INDIVIDUAL ITEMS

8 THIRD ANGLE PROJECTION
DO NOT SCALE DRAWING

NOTE:
ALL ITEMS ARE TO BE PAINTED
INDIVIDUALLY. ALL SCREW THREADS
ARE TO BE COVERED BEFORE PAINTING.
COUPLERS ARE NOT TO BE PAINTED.

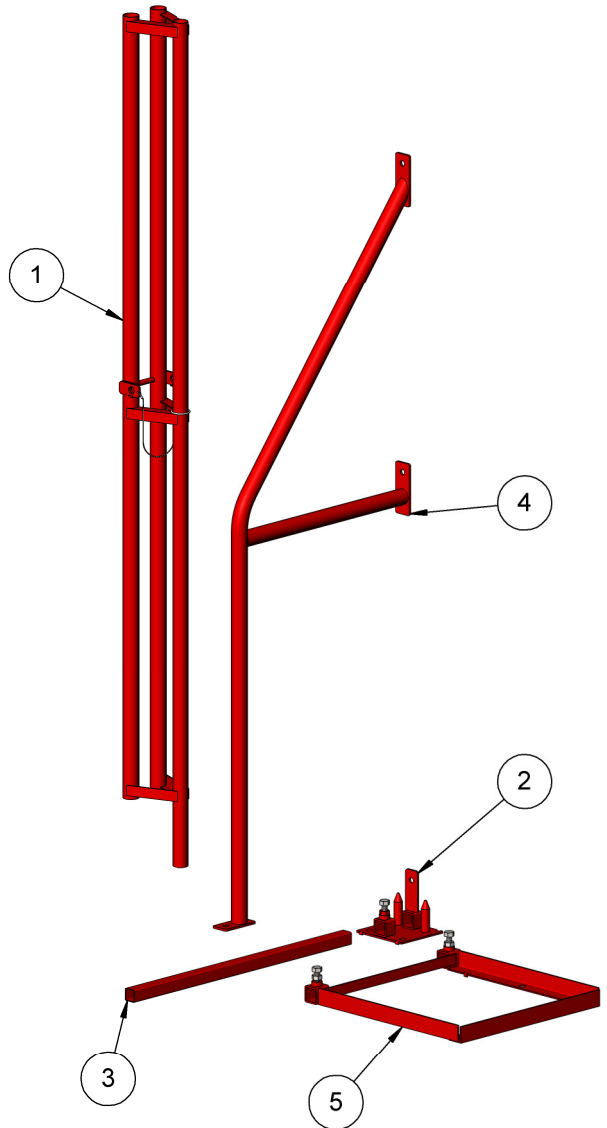

ITEM No.	PART No.	DESCRIPTION	QTY
1	ZND1349-2	LOCKING END FAB	1
2	16552096	WINDBREAKER ZERO-TRIP FOOT	1
3	16552098	WINDBREAKER BOTTOM TUBE - REDUCED	1
4	16552099	WINDBREAKER STABILISER - REDUCED	1
5	16552100	WINDBREAKER BLOCK TRAY	1

P2	17/4/19	ISSUED FOR APPROVAL	GC	.	.
P1	26/3/19	ISSUED FOR APPROVAL	GC	.	.
REV	DATE	DESCRIPTION	DRN	CHKD	APPR

TOLERANCES - UNLESS STATED OTHERWISE			TITLE: SLIDING GATE LOCKING END PARTS TO BE PAINTED		
FABRICATION	UP TO 300mm	+/- 1mm	DRAWN	G. CRICK	26/3/19
	UP TO 1000mm	+/- 2mm			
	1001mm & ABOVE	+/- 3mm			
MACHINING	ANGULAR	+/- 1°	CHK'D		
	GAUGE	+/- 10%	FINISH: PAINT POLYESTER POWDERCOAT. COLOUR RAL3020: GUARDS RED		
WEIGHT	+/- 10% (DUE TO MATERIAL PROPERTIES & TOLERANCES)		MATERIAL: CARBON STEEL PRE-GALVANISED		

RIDGEWAY

Belfast: +44 (0) 28 90454599
 Ashbourne: +353 (01) 802 7173
 Email: info@ridgeway-online.com
 Web: www.ridgeway-online.com

P2

THE COMPANY RETAIN THE RIGHT TO PERIODICALLY ALTER INFORMATION WITHIN THIS DRAWING SHEET AND WILL ATTEMPT TO NOTIFY ALL PARTIES CONCERNED OF ANY CHANGES AND THE INFORMATION ON THIS SHEET SHOULD NOT BE REPRODUCED WITHOUT THEIR WRITTEN CONSENT.

1
ALL DIMENSIONS IN MILLIMETRES
REMOVE ALL SHARP EDGES

2
DO NOT JOIN MATERIAL TOGETHER
TO MAKE INDIVIDUAL ITEMS

8
THIRD ANGLE PROJECTION
DO NOT SCALE DRAWING

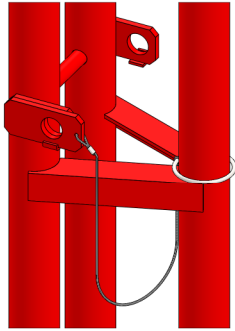

LATCH IN LOCKED POSITION

NOTE:
LATCH CAN BE TURNED 90°
SO THAT A LOCK CAN BE PUT
THROUGH THE HOLES IN THE
LATCH AND THE LOCKING TABS
ON THE TUBES. THIS CAN BE DONE
ON EITHER SIDE SO THE GATE CAN
BE LOCKED FROM BOTH SIDES.

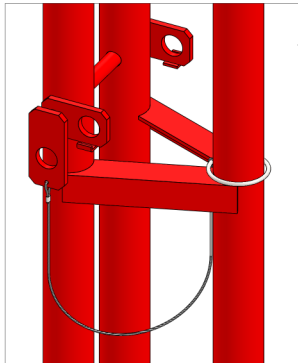

LATCH IN UNLOCKED POSITION

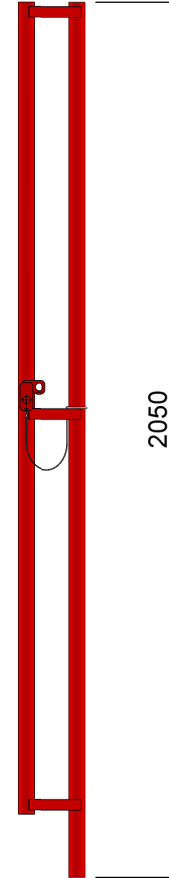
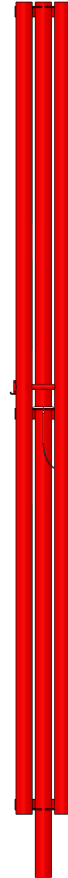
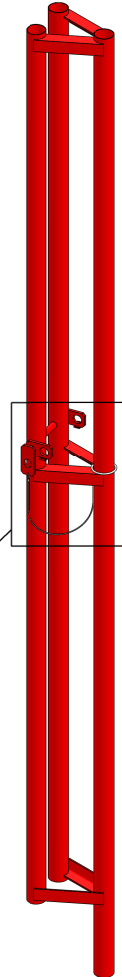

2050

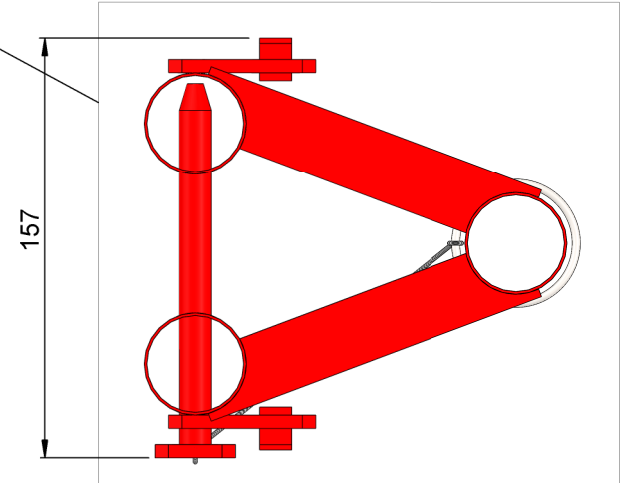

157

P2	18/4/19	ISSUED FOR APPROVAL	GC	.	.
P1	11/3/19	ISSUED FOR APPROVAL	GC	.	.
REV	DATE	DESCRIPTION	DRN	CHKD	APPR

TOLERANCES - UNLESS STATED OTHERWISE

FABRICATION	UP TO 300mm	+/- 1mm
	UP TO 1000mm	+/- 2mm
	1001mm & ABOVE	+/- 3mm
	ANGULAR	+/- 1°
MACHINING	+/- 0.2mm	
GAUGE	+/- 10%	
WEIGHT	+/- 10% (DUE TO MATERIAL PROPERTIES & TOLERANCES)	

TITLE: **SLIDING GATE LOCKING END + STABILISER**

DRAWN	G. CRICK	DATE	11/3/19
CHK'D			
FINISH: PAINT POLYESTER POWDERCOAT. COLOUR RAL3020: GUARDS RED			



Belfast: +44 (0) 28 90454599
Ashbourne: +353 (01) 802 7173
Email: info@ridgeway-online.com
Web: www.ridgeway-online.com

Revision

P2

THE COMPANY RETAIN THE RIGHT TO PERIODICALLY ALTER INFORMATION WITHIN THIS DRAWING SHEET AND WILL ATTEMPT TO NOTIFY ALL PARTIES CONCERNED OF ANY CHANGES AND THE INFORMATION ON THIS SHEET SHOULD NOT BE REPRODUCED WITHOUT THEIR WRITTEN CONSENT.

1
ALL DIMENSIONS IN MILLIMETRES
REMOVE ALL SHARP EDGES

2
DO NOT JOIN MATERIAL TOGETHER
TO MAKE INDIVIDUAL ITEMS

8
THIRD ANGLE PROJECTION
DO NOT SCALE DRAWING

NOTE:
THE SLIP RING OF THE LATCH
IS TO BE PUT ONTO THIS TUBE
BEFORE THE TOP ANGLES ARE
WELDED IN POSITION. DO NOT
WELD THE SLIP RING ONTO
THE TUBE.

NOTE:
THESE 2 ANGLES ARE TO
BE WELDED IN POSITION
AFTER THE LATCH SLIP
RING HAS BEEN PLACED
OVER THIS TUBE.

NOTE:
LATCH FABRICATION IS TO BE
FREE TO BE MOVED FROM THIS
SIDE TO THE OTHER SIDE SO
THAT THE LOCK CAN BE USED
FROM BOTH SIDES.

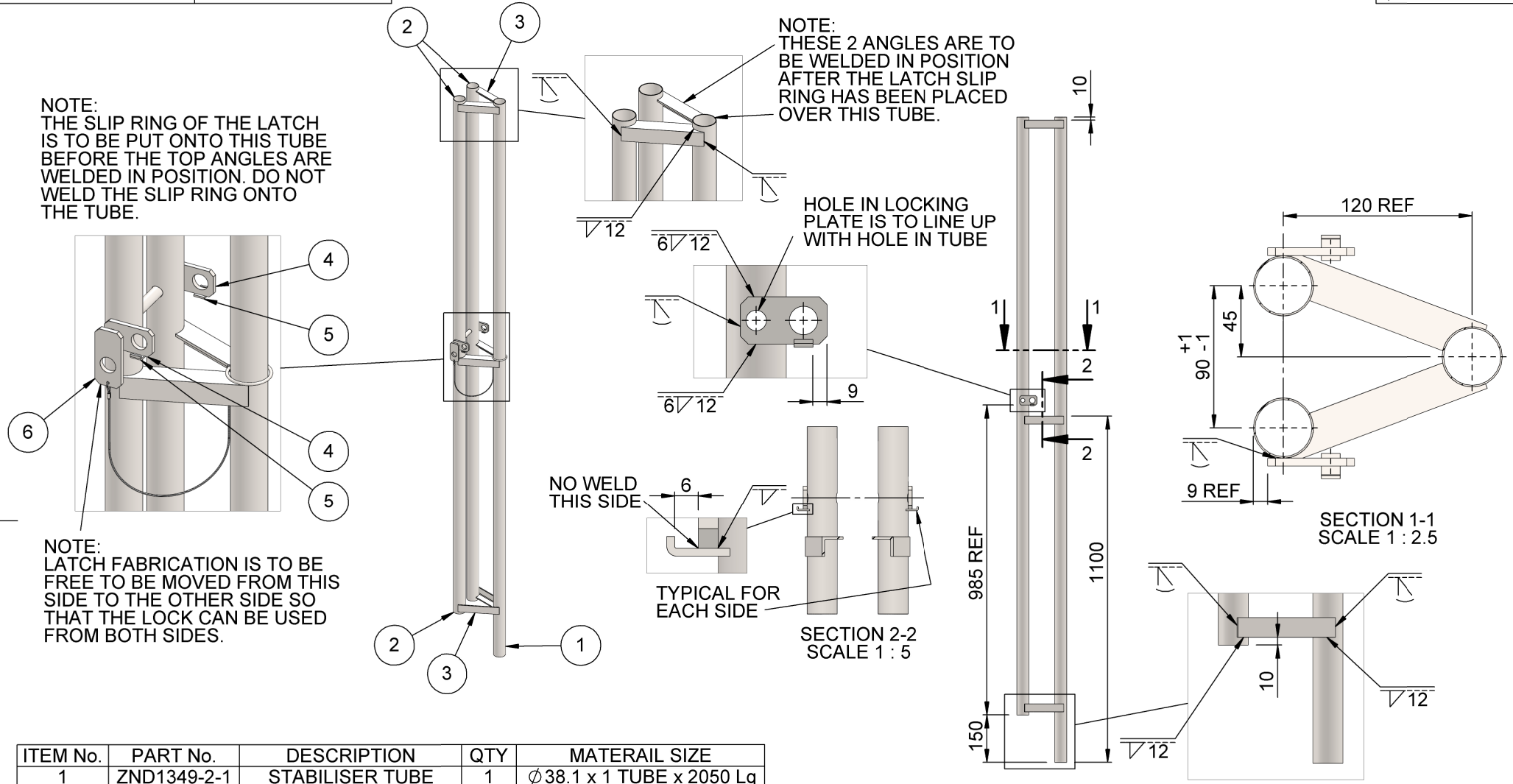

ITEM No.	PART No.	DESCRIPTION	QTY	MATERIAL SIZE
1	ZND1349-2-1	STABILISER TUBE	1	∅38.1 x 1 TUBE x 2050 Lg
2	ZND1349-2-2	GUIDE TUBE	2	SEE DETAIL
3	ZND1349-2-3	GUIDE TUBE SUPPORT	6	SEE DETAIL
4	ZND1349-2-4	LOCKING PLATE	2	SEE DETAIL
5	ZND1349-2-5	LOCKING PLATE TAB	2	SEE DETAIL
6	ZND1349-2-6	LATCH FABRICATION	1	SEE DETAIL

REV	DATE	DESCRIPTION	DRN	CHKD	APPR
P2	18/4/19	ISSUED FOR MANUFACTURE	GC		
P1	11/3/19	ISSUED FOR APPROVAL	GC		

TOLERANCES - UNLESS STATED OTHERWISE

FABRICATION	UP TO 300mm	+/- 1mm
	UP TO 1000mm	+/- 2mm
	1001mm & ABOVE	+/- 3mm
ANGULAR	+/- 1°	
MACHINING	+/- 0.2mm	
GAUGE	+/- 10%	
WEIGHT	+/- 10% (DUE TO MATERIAL PROPERTIES & TOLERANCES)	

TITLE: **SLIDING GATE LOCKING END**

NAME	SIGNATURE	DATE	MATERIAL:
DRAWN G. CRICK		11/3/19	CARBON STEEL PRE-GALVANISED
CHK'D			
FINISH: NONE			



Belfast: +44 (0) 28 90454599
 Ashbourne: +353 (01) 802 7173
 Email: info@ridgeway-online.com
 Web: www.ridgeway-online.com

Revision
P2

THE COMPANY RETAIN THE RIGHT TO PERIODICALLY ALTER INFORMATION WITHIN THIS DRAWING SHEET AND WILL ATTEMPT TO NOTIFY ALL PARTIES CONCERNED OF ANY CHANGES AND THE INFORMATION ON THIS SHEET SHOULD NOT BE REPRODUCED WITHOUT THEIR WRITTEN CONSENT.

1 ALL DIMENSIONS IN MILLIMETRES
REMOVE ALL SHARP EDGES

2 DO NOT JOIN MATERIAL TOGETHER
TO MAKE INDIVIDUAL ITEMS

8 THIRD ANGLE PROJECTION
DO NOT SCALE DRAWING

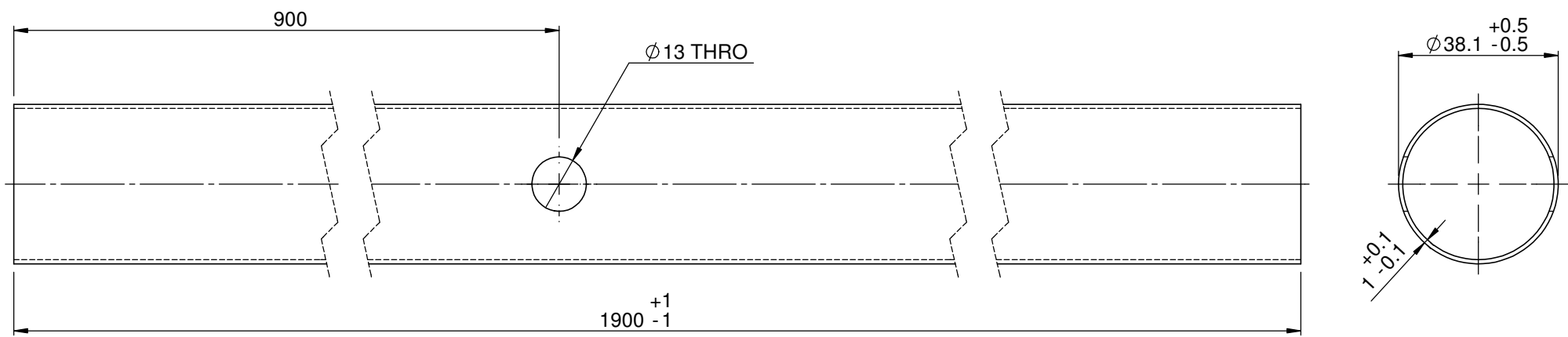

P2	18/4/19	ISSUED FOR APPROVAL	GC	.	.
P1	11/3/19	ISSUED FOR APPROVAL	GC	.	.
REV	DATE	DESCRIPTION	DRN	CHKD	APPR

TOLERANCES - UNLESS STATED OTHERWISE

FABRICATION	UP TO 300mm	+/- 1mm
	UP TO 1000mm	+/- 2mm
	1001mm & ABOVE	+/- 3mm
	ANGULAR	+/- 1°
MACHINING	+/- 0.2mm	
GAUGE	+/- 10%	
WEIGHT	+/- 10% (DUE TO MATERIAL PROPERTIES & TOLERANCES)	

TITLE: **SLIDING GATE LOCKING END GUIDE TUBE**

NAME	SIGNATURE	DATE	MATERIAL:
G. CRICK		11/3/19	CARBON STEEL PRE-GALVANISED
CHK'D			
FINISH:			NONE



Belfast: +44 (0) 28 90454599
 Ashbourne: +353 (01) 802 7173
 Email: info@ridgeway-online.com
 Web: www.ridgeway-online.com

Revision **P2**

THE COMPANY RETAIN THE RIGHT TO PERIODICALLY ALTER INFORMATION WITHIN THIS DRAWING SHEET AND WILL ATTEMPT TO NOTIFY ALL PARTIES CONCERNED OF ANY CHANGES AND THE INFORMATION ON THIS SHEET SHOULD NOT BE REPRODUCED WITHOUT THEIR WRITTEN CONSENT.

1 ALL DIMENSIONS IN MILLIMETRES
REMOVE ALL SHARP EDGES

2 DO NOT JOIN MATERIAL TOGETHER
TO MAKE INDIVIDUAL ITEMS

8 THIRD ANGLE PROJECTION
DO NOT SCALE DRAWING

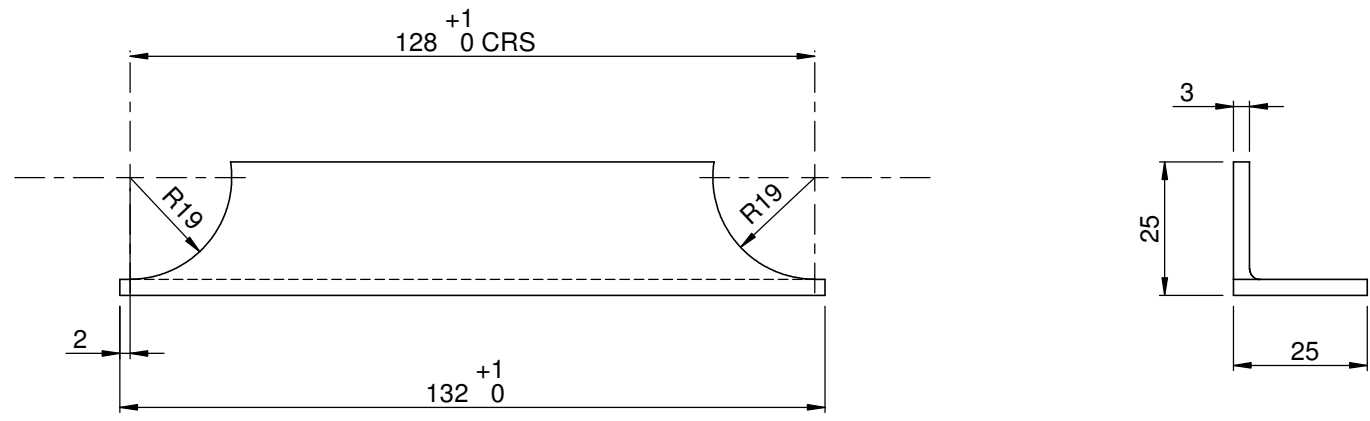

CUT FROM 25 x 25 x 3 RSA

P2	18/4/19	ISSUED FOR APPROVAL	GC	.	.
P1	11/3/19	ISSUED FOR APPROVAL	GC	.	.
REV	DATE	DESCRIPTION	DRN	CHKD	APPR

TOLERANCES - UNLESS STATED OTHERWISE

FABRICATION	UP TO 300mm	+/- 1mm
	UP TO 1000mm	+/- 2mm
	1001mm & ABOVE	+/- 3mm
	ANGULAR	+/- 1°
MACHINING	+/- 0.2mm	
GAUGE	+/- 10%	
WEIGHT	+/- 10% (DUE TO MATERIAL PROPERTIES & TOLERANCES)	

TITLE: **SLIDING GATE LOCKING END GUIDE TUBE SUPPORT**

NAME	SIGNATURE	DATE	MATERIAL:
G. CRICK		11/3/19	CARBON STEEL PRE-GALVANISED
CHK'D			
FINISH:			NONE

RIDGEWAY

Belfast: +44 (0) 28 90454599
 Ashbourne: +353 (01) 802 7173
 Email: info@ridgeway-online.com
 Web: www.ridgeway-online.com

Revision **P2**

THE COMPANY RETAIN THE RIGHT TO PERIODICALLY ALTER INFORMATION WITHIN THIS DRAWING SHEET AND WILL ATTEMPT TO NOTIFY ALL PARTIES CONCERNED OF ANY CHANGES AND THE INFORMATION ON THIS SHEET SHOULD NOT BE REPRODUCED WITHOUT THEIR WRITTEN CONSENT.

1 ALL DIMENSIONS IN MILLIMETRES
REMOVE ALL SHARP EDGES

2 DO NOT JOIN MATERIAL TOGETHER
TO MAKE INDIVIDUAL ITEMS

8 THIRD ANGLE PROJECTION
DO NOT SCALE DRAWING

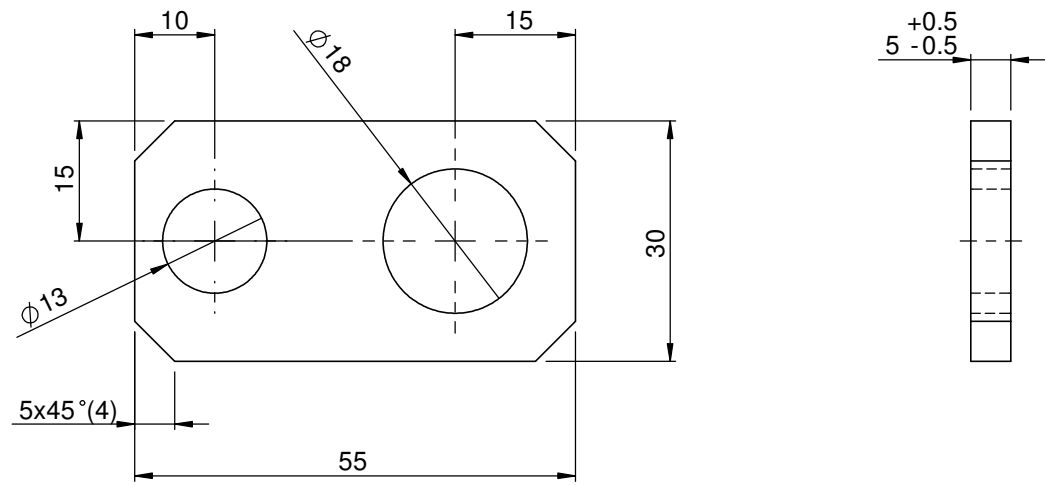

P2	18/4/19	ISSUED FOR APPROVAL	GC	.	.
P1	11/3/19	ISSUED FOR APPROVAL	GC	.	.
REV	DATE	DESCRIPTION	DRN	CHKD	APPR

TOLERANCES - UNLESS STATED OTHERWISE

FABRICATION	UP TO 300mm	+/- 1mm
	UP TO 1000mm	+/- 2mm
	1001mm & ABOVE	+/- 3mm
	ANGULAR	+/- 1°
MACHINING	+/- 0.2mm	
GAUGE	+/- 10%	
WEIGHT	+/- 10% (DUE TO MATERIAL PROPERTIES & TOLERANCES)	

TITLE: **SLIDING GATE LOCKING END LOCKING PLATE**

NAME	SIGNATURE	DATE
G. CRICK		11/3/19
CHK'D		
FINISH:	NONE	

RIDGWAY

Belfast: +44 (0) 28 90454599
 Ashbourne: +353 (01) 802 7173
 Email: info@ridgeway-online.com
 Web: www.ridgeway-online.com

Revision **P2**

THE COMPANY RETAIN THE RIGHT TO PERIODICALLY ALTER INFORMATION WITHIN THIS DRAWING SHEET AND WILL ATTEMPT TO NOTIFY ALL PARTIES CONCERNED OF ANY CHANGES AND THE INFORMATION ON THIS SHEET SHOULD NOT BE REPRODUCED WITHOUT THEIR WRITTEN CONSENT.

1 ALL DIMENSIONS IN MILLIMETRES
REMOVE ALL SHARP EDGES

2 DO NOT JOIN MATERIAL TOGETHER
TO MAKE INDIVIDUAL ITEMS

THIRD ANGLE PROJECTION
DO NOT SCALE DRAWING

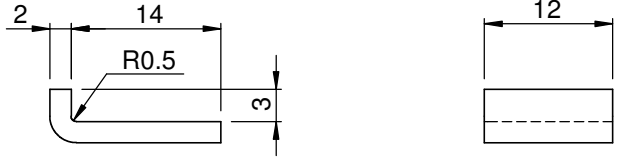

P1	11/3/19	ISSUED FOR APPROVAL	GC		
REV	DATE	DESCRIPTION	DRN	CHKD	APPR

TOLERANCES - UNLESS STATED OTHERWISE

FABRICATION	UP TO 300mm	+/- 1mm
	UP TO 1000mm	+/- 2mm
	1001mm & ABOVE	+/- 3mm
	ANGULAR	+/- 1°
MACHINING	+/- 0.2mm	
GAUGE	+/- 10%	
WEIGHT	+/- 10% (DUE TO MATERIAL PROPERTIES & TOLERANCES)	

TITLE: **SLIDING GATE LOCKING END LOCKING PLATE TAB**

NAME	SIGNATURE	DATE
G. CRICK		11/3/19
CHK'D		
FINISH:	NONE	

MATERIAL: **CARBON STEEL PRE-GALVANISED**



Belfast: +44 (0) 28 90454599
 Ashbourne: +353 (01) 802 7173
 Email: info@ridgeway-online.com
 Web: www.ridgeway-online.com

REVISION
P1

THE COMPANY RETAIN THE RIGHT TO PERIODICALLY ALTER INFORMATION WITHIN THIS DRAWING SHEET AND WILL ATTEMPT TO NOTIFY ALL PARTIES CONCERNED OF ANY CHANGES AND THE INFORMATION ON THIS SHEET SHOULD NOT BE REPRODUCED WITHOUT THEIR WRITTEN CONSENT.

1
ALL DIMENSIONS IN MILLIMETRES
REMOVE ALL SHARP EDGES

2
DO NOT JOIN MATERIAL TOGETHER
TO MAKE INDIVIDUAL ITEMS

8
THIRD ANGLE PROJECTION
DO NOT SCALE DRAWING

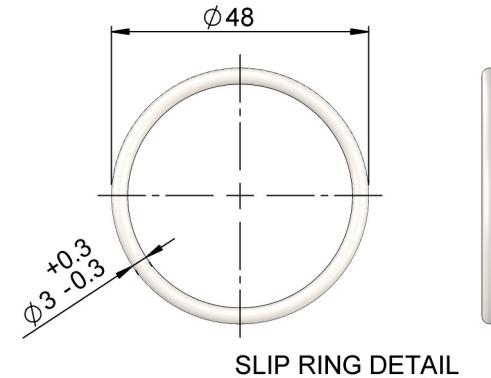
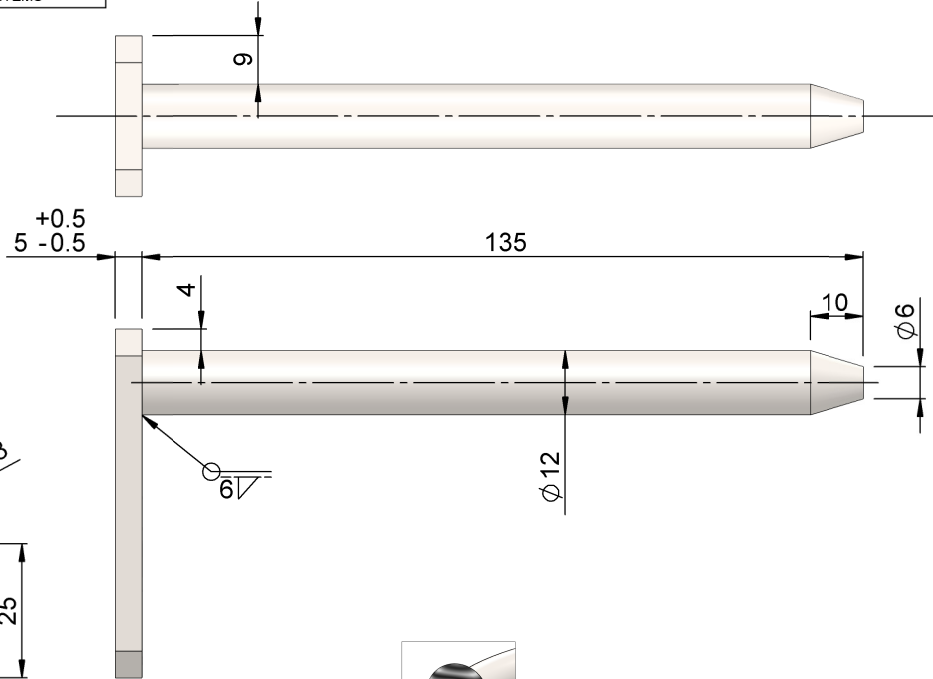
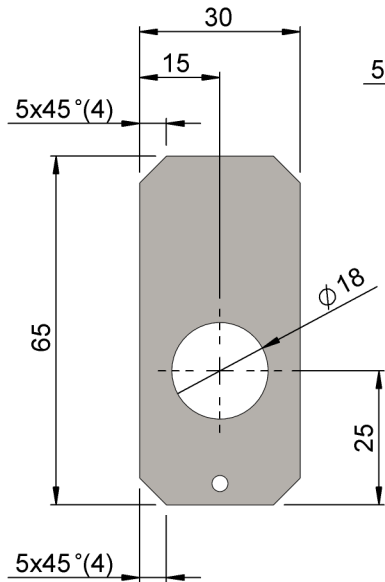

LATCH TO BE PAINTED

USE WIRE CRIMP AT THIS END AS WEEL TO JOIN THE WIRE.

USE 1mm DIAMETER GALVANISED STEEL WIRE x 330mm LONG

WIRE TO BE PUT THROUGH HOLE IN LATCH PLATE. THE JOINT IS THE MADE USING A WIRE CRIMP AS SHOWN HERE.

P2	18/4/19	ISSUED FOR APPROVAL	GC	.	.
P1	11/3/19	ISSUED FOR APPROVAL	GC	.	.
REV	DATE	DESCRIPTION	DRN	CHKD	APPR

TOLERANCES - UNLESS STATED OTHERWISE			TITLE: SLIDING GATE LOCKING END LATCH			
FABRICATION	UP TO 300mm	+/- 1mm	DRAWN	NAME	SIGNATURE	
	UP TO 1000mm	+/- 2mm				DATE
	1001mm & ABOVE	+/- 3mm				
	ANGULAR	+/- 1°	CHK'D			
MACHINING	+/- 0.2mm		FINISH: PAINT POLYESTER			
GAUGE	+/- 10%		POWDERCOAT. COLOUR RAL3020: GUARDS RED			
WEIGHT	+/- 10% (DUE TO MATERIAL PROPERTIES & TOLERANCES)		MATERIAL: CARBON STEEL PRE-GALVANISED			

RIDGEWAY

Belfast: +44 (0) 28 90454599
Ashbourne: +353 (01) 802 7173
Email: info@ridgeway-online.com
Web: www.ridgeway-online.com

Revision

P2

THE COMPANY RETAIN THE RIGHT TO PERIODICALLY ALTER INFORMATION WITHIN THIS DRAWING SHEET AND WILL ATTEMPT TO NOTIFY ALL PARTIES CONCERNED OF ANY CHANGES AND THE INFORMATION ON THIS SHEET SHOULD NOT BE REPRODUCED WITHOUT THEIR WRITTEN CONSENT.

1 ALL DIMENSIONS IN MILLIMETRES
REMOVE ALL SHARP EDGES

2 DO NOT JOIN MATERIAL TOGETHER
TO MAKE INDIVIDUAL ITEMS

8 THIRD ANGLE PROJECTION
DO NOT SCALE DRAWING

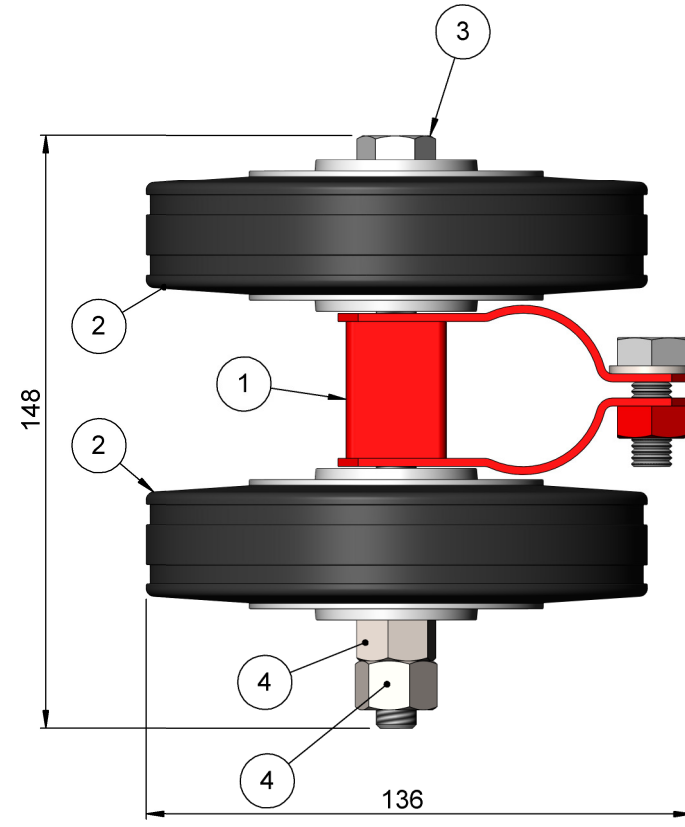

ITEM No.	PART No.	DESCRIPTION	QTY
1	ZND1349-3-1	WHEEL CLAMP FAB	1
2	ZND1349-3-2	CASTOR WHEEL. 125 Ø	2
3		M10 HEX HD BOLT x 140 Lg	1
4		M10 LOCKNUT	2
5		M10 PLAIN WASHER	3
6		M10 x 25 HEX HD BOLT	1

P2	18/4/19	ISSUED FOR APPROVAL	GC	.	.
P1	11/3/19	ISSUED FOR APPROVAL	GC	.	.
REV	DATE	DESCRIPTION	DRN	CHKD	APPR

TOLERANCES - UNLESS STATED OTHERWISE			TITLE: SLIDING GATE WHEEL CLAMP - ASSEMBLY		
FABRICATION	UP TO 300mm	+/- 1mm	DRAWN	NAME	SIGNATURE
	UP TO 1000mm	+/- 2mm		G. CRICK	
	1001mm & ABOVE	+/- 3mm		DATE	11/3/19
	ANGULAR	+/- 1°	CHK'D		
MACHINING	+/- 0.2mm		FINISH:	PAINT POLYESTER POWDERCOAT. COLOUR RAL3020: GUARDS RED	
GAUGE	+/- 10%		MATERIAL:	CARBON STEEL PRE-GALVANISED	
WEIGHT	+/- 10% (DUE TO MATERIAL PROPERTIES & TOLERANCES)				

RIDGEWAY

Belfast: +44 (0) 28 90454599
 Ashbourne: +353 (01) 802 7173
 Email: info@ridgeway-online.com
 Web: www.ridgeway-online.com

Revision **P2**

THE COMPANY RETAIN THE RIGHT TO PERIODICALLY ALTER INFORMATION WITHIN THIS DRAWING SHEET AND WILL ATTEMPT TO NOTIFY ALL PARTIES CONCERNED OF ANY CHANGES AND THE INFORMATION ON THIS SHEET SHOULD NOT BE REPRODUCED WITHOUT THEIR WRITTEN CONSENT.

1
ALL DIMENSIONS IN MILLIMETRES
REMOVE ALL SHARP EDGES

2
DO NOT JOIN MATERIAL TOGETHER
TO MAKE INDIVIDUAL ITEMS

8
THIRD ANGLE PROJECTION
DO NOT SCALE DRAWING

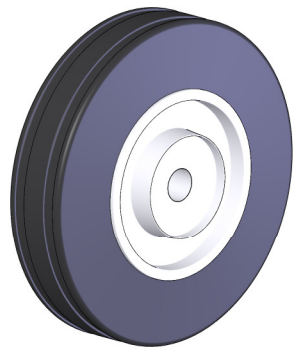
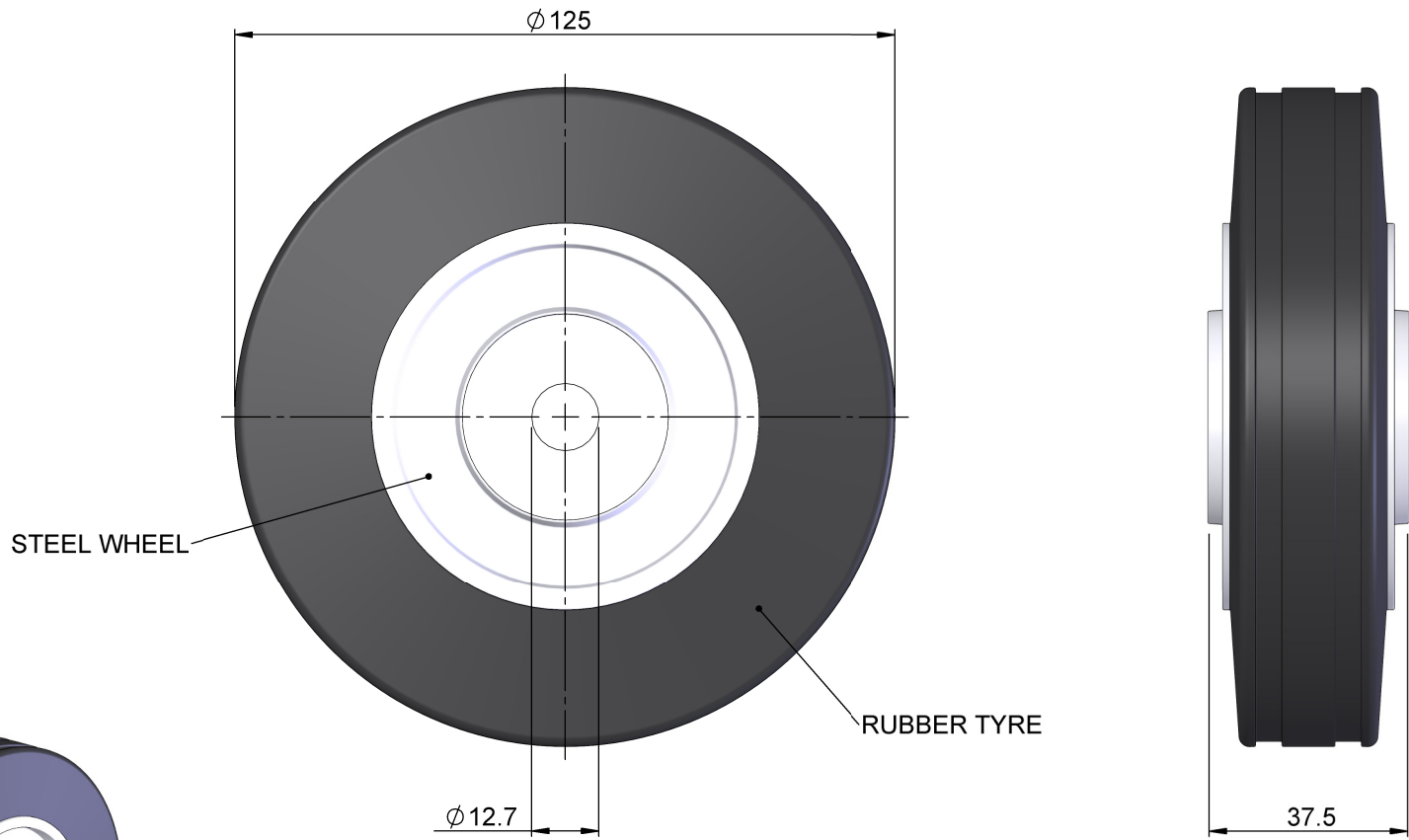

APROXIMATE DETAIL OF CASTER WHEEL

P2	18/4/19	ISSUED FOR APPROVAL	GC	.	.
P1	11/3/19	ISSUED FOR APPROVAL	GC	.	.
REV	DATE	DESCRIPTION	DRN	CHKD	APPR

TOLERANCES - UNLESS STATED OTHERWISE		
FABRICATION	UP TO 300mm	+/- 1mm
	UP TO 1000mm	+/- 2mm
	1001mm & ABOVE	+/- 3mm
	ANGULAR	+/- 1°
MACHINING	+/- 0.2mm	
GAUGE	+/- 10%	
WEIGHT	+/- 10% (DUE TO MATERIAL PROPERTIES & TOLERANCES)	

TITLE: SLIDING GATE ϕ 125 WHEEL			
DRAWN	NAME	SIGNATURE	DATE
CHK'D			11/3/19
FINISH: AS SUPPLIED			
MATERIAL: AS SUPPLIED			



Belfast: +44 (0) 28 90454599
 Ashbourne: +353 (01) 802 7173
 Email: info@ridgeway-online.com
 Web: www.ridgeway-online.com

Revision
P2

THE COMPANY RETAIN THE RIGHT TO PERIODICALLY ALTER INFORMATION WITHIN THIS DRAWING SHEET AND WILL ATTEMPT TO NOTIFY ALL PARTIES CONCERNED OF ANY CHANGES AND THE INFORMATION ON THIS SHEET SHOULD NOT BE REPRODUCED WITHOUT THEIR WRITTEN CONSENT.

1
ALL DIMENSIONS IN MILLIMETRES
REMOVE ALL SHARP EDGES

2
DO NOT JOIN MATERIAL TOGETHER
TO MAKE INDIVIDUAL ITEMS

8
THIRD ANGLE PROJECTION
DO NOT SCALE DRAWING

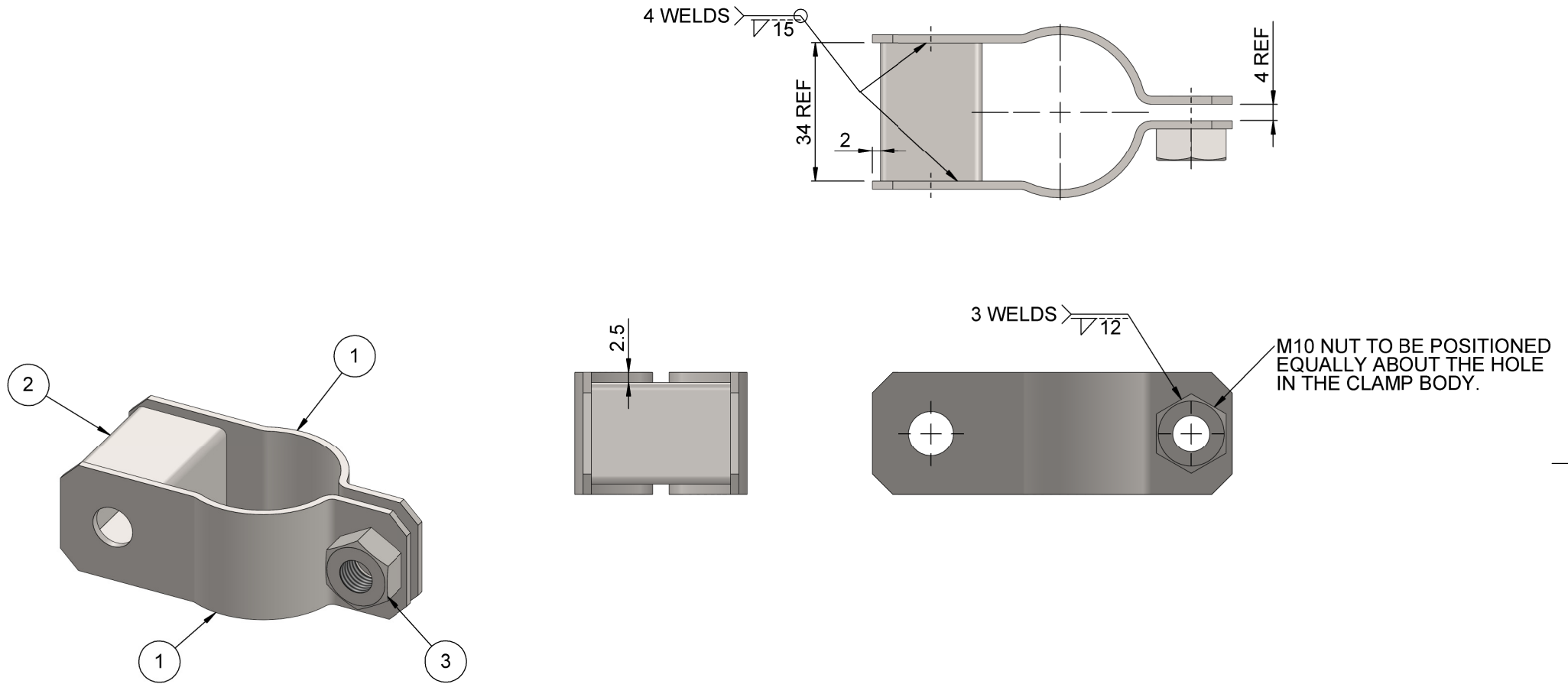

ITEM No.	PART No.	DESCRIPTION	QTY	MATERIAL SIZE
1	ZND1349-3-1-1	CLAMP BODY HALF	2	SEE DETAIL
2	ZND1349-3-1-2	SPACER TUBE	1	25 x 25 x 2 SHS x 34 Lg
3	ZND1349-3-1-3	M10 FULL NUT	1	

REV	DATE	DESCRIPTION	DRN	CHKD	APPR
P2	18/4/19	ISSUED FOR APPROVAL	GC	.	.
P1	11/3/19	ISSUED FOR APPROVAL	GC	.	.

TOLERANCES - UNLESS STATED OTHERWISE

FABRICATION	UP TO 300mm	+/- 1mm
	UP TO 1000mm	+/- 2mm
	1001mm & ABOVE	+/- 3mm
	ANGULAR	+/- 1°
MACHINING	+/- 0.2mm	
GAUGE	+/- 10%	
WEIGHT	+/- 10% (DUE TO MATERIAL PROPERTIES & TOLERANCES)	

TITLE: **SLIDING GATE WHEEL CLAMP - FABRICATION**

NAME	SIGNATURE	DATE	MATERIAL:
DRAWN G. CRICK		11/3/19	CARBON STEEL PRE-GALVANISED
CHK'D			
FINISH:			NONE



Belfast: +44 (0) 28 90454599
Ashbourne: +353 (01) 802 7173
Email: info@ridgeway-online.com
Web: www.ridgeway-online.com

Revision

P2

THE COMPANY RETAIN THE RIGHT TO PERIODICALLY ALTER INFORMATION WITHIN THIS DRAWING SHEET AND WILL ATTEMPT TO NOTIFY ALL PARTIES CONCERNED OF ANY CHANGES AND THE INFORMATION ON THIS SHEET SHOULD NOT BE REPRODUCED WITHOUT THEIR WRITTEN CONSENT.

1
ALL DIMENSIONS IN MILLIMETRES
REMOVE ALL SHARP EDGES

2
DO NOT JOIN MATERIAL TOGETHER
TO MAKE INDIVIDUAL ITEMS

8
THIRD ANGLE PROJECTION
DO NOT SCALE DRAWING

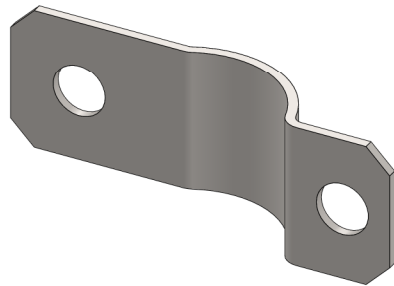
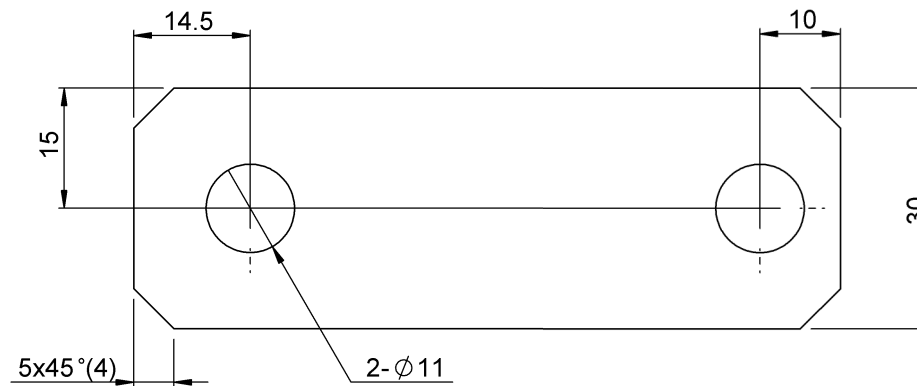
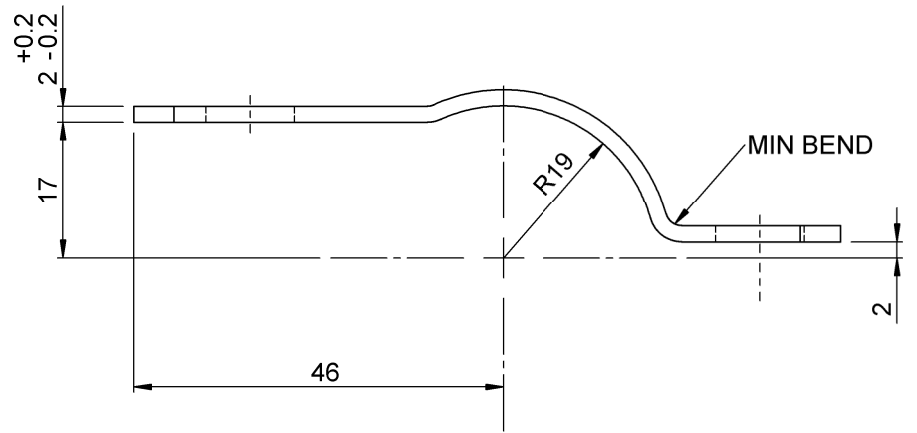

P2	18/4/19	ISSUED FOR APPROVAL	GC	.	.
P1	11/3/19	ISSUED FOR APPROVAL	GC	.	.
REV	DATE	DESCRIPTION	DRN	CHKD	APPR

TOLERANCES - UNLESS STATED OTHERWISE		
FABRICATION	UP TO 300mm	+/- 1mm
	UP TO 1000mm	+/- 2mm
	1001mm & ABOVE	+/- 3mm
	ANGULAR	+/- 1°
MACHINING	+/- 0.2mm	
GAUGE	+/- 10%	
WEIGHT	+/- 10% (DUE TO MATERIAL PROPERTIES & TOLERANCES)	

TITLE: SLIDING GATE WHEEL CLAMP - BODY HALF			
NAME	SIGNATURE	DATE	MATERIAL:
G. CRICK		11/3/19	CARBON STEEL PRE-GALVANISED
CHK'D			
FINISH: NONE			

RIDGWAY

Belfast: +44 (0) 28 90454599
 Ashbourne: +353 (01) 802 7173
 Email: info@ridgeway-online.com
 Web: www.ridgeway-online.com

Revision **P2**

THE COMPANY RETAIN THE RIGHT TO PERIODICALLY ALTER INFORMATION WITHIN THIS DRAWING SHEET AND WILL ATTEMPT TO NOTIFY ALL PARTIES CONCERNED OF ANY CHANGES AND THE INFORMATION ON THIS SHEET SHOULD NOT BE REPRODUCED WITHOUT THEIR WRITTEN CONSENT.